

REV.	DESCRIPTION	DATE
A	release	11/30/2012

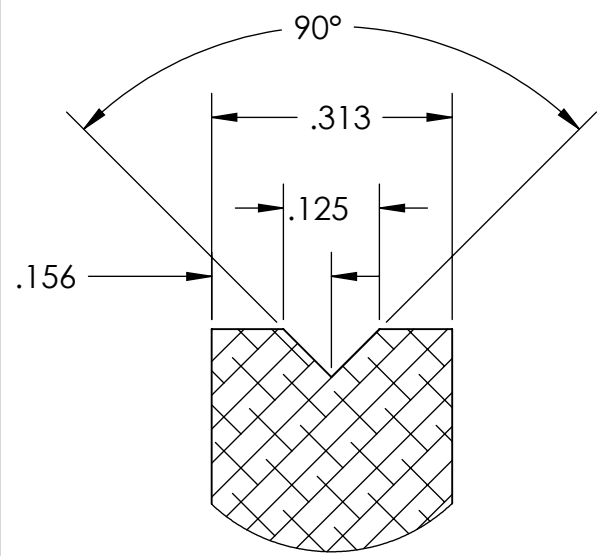
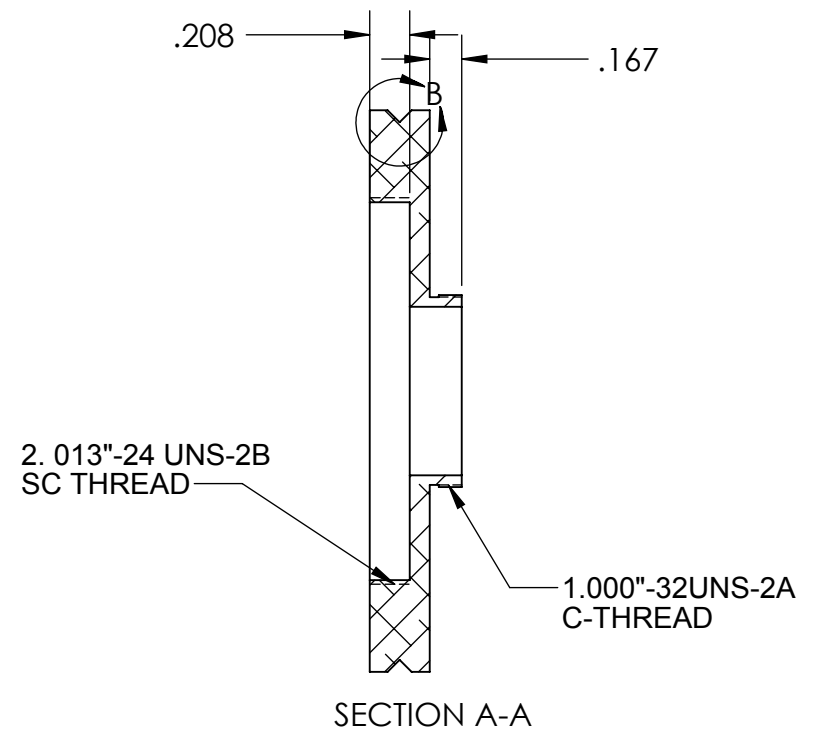
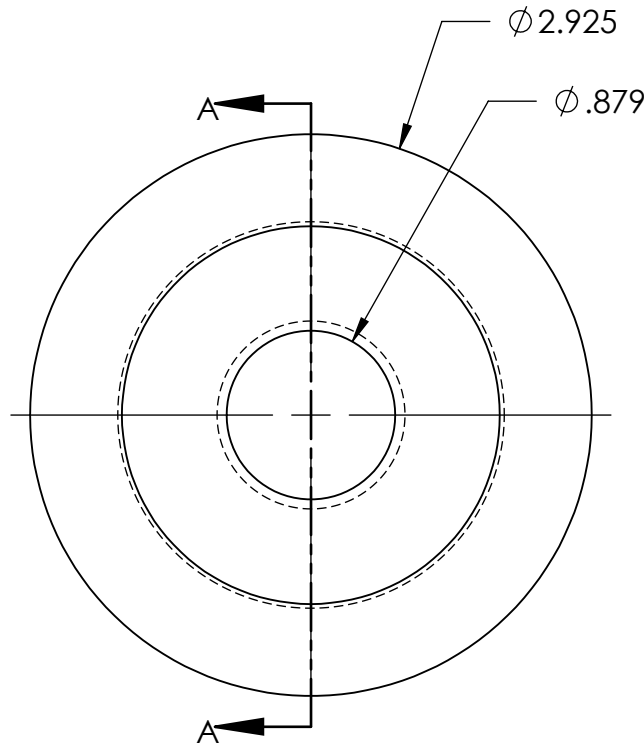

DETAIL B
SCALE 4 : 1

ADPT_CFW_C_AD41_21999

PROPRIETARY AND CONFIDENTIAL:
THE INFORMATION CONTAINED IN THIS DRAWING IS THE SOLE
PROPERTY OF FINGER LAKES INSTRUMENTATION. ANY
REPRODUCTION IN PART OR AS AWHOLE WITHOUT THE WRITTEN
PERMISSION OF FINGER LAKES INSTRUMENTATION
IS PROHIBITED.

	NAME	DATE	SIZE	A	UNLESS OTHERWISE SPECIFIED: DIMENSIONS ARE IN INCHES TOLERANCES: ANGULAR: $\pm 1^\circ$ TWO PLACE DECIMAL $\pm .01$ THREE PLACE DECIMAL $\pm .003$ FOUR PLACE DECIMAL $\pm .0005$	REV	A
DRAWN	REC	11/30/12	MATERIAL:			FINISH:	
CHECKED			6061 Alloy			SEBA	
DO NOT SCALE DRAWING			SCALE: 1:1	WEIGHT: 0.14	SHEET 1 OF 1		