



iOptron[®] CEM25 Center Balanced Equatorial Mount

Instruction Manual

Product #7100E, #7102E, #7100-EC, #7102-EC



Read the included CEM25 Quick Setup Guide (QSG) BEFORE taking the mount out of the case!

This product is a precision instrument and uses a magnetic gear meshing mechanism. Please read the included QSG before assembling the mount. Please read the entire Instruction Manual before operating the mount.

You must hold the mount firmly when disengaging or adjusting the gear switches. Otherwise personal injury and/or equipment damage may occur. Any worm system damage due to improper gear meshing/slippage will not be covered by iOptron's limited warranty.

If you have any questions please contact us at support@ioptron.com



WARNING!

***NEVER USE A TELESCOPE TO LOOK AT THE SUN WITHOUT A PROPER FILTER!
Looking at or near the Sun will cause instant and irreversible damage to your eye.
Children should always have adult supervision while observing.***

Table of Content

Table of Content	3
1. CEM25 Overview	5
2. CEM25 Terms	7
2.1. Parts List	7
2.2. Assembly Terms	8
2.3. CEM25 Ports	9
2.4. Go2Nova [®] 8408 Hand Controller	9
2.4.1. Key Description	10
2.4.2. The LCD Screen	10
2.5. Check the Battery	11
2.6. Bench Testing the Mount	11
3. CEM25 Mount Assembly	13
3.1. Introduction	13
3.2. CEM25 Mount Assembly	13
4. Getting Started	23
4.1. Setup the Mount and Polar Alignment	23
4.2. Manual Operation of the Mount	23
4.3. Initial Star Alignment	23
4.4. Go to the Moon and Other Stars	23
4.5. Star Identifying Function	24
4.6. Gear Tension Adjustment	24
4.7. GOTO and Tracking Position Memorization	24
4.8. Turn Off the Mount	24
5. Complete Functions of Go2Nova [®] 8408 Hand Controller	25
5.1. Slew to an Object	25
5.1.1. Solar System	25
5.1.2. Deep Sky Objects	25
5.1.3. Stars:	25
5.1.4. Constellations	25
5.1.5. Comets	25
5.1.6. Asteroids	25
5.1.7. User Objects	26
5.1.8. Enter R.A. DEC	26
5.2. Sync to Target	26
5.3. Alignment	26
5.3.1. Pole Star Position	26
5.3.2. One Star Alignment	26
5.3.3. Two Star Polar Align	26
5.3.4. Three Star Align	27
5.3.5. Polar Iterate Align	27
5.3.6. Solar System Align	27
5.3.7. Display Model Error	27
5.3.8. Clear Alignment Data	27
5.4. Settings	28
5.4.1. Set Time and Site	28
5.4.2. Set Beep	28
5.4.3. Set Display	28

5.4.4. Set Guiding Rate.....	28
5.4.5. Set Tracking Rate	29
5.4.6. Meridian Treatment.....	29
5.4.7. Track Below Horizon	29
5.4.8. Set Eyepiece Light.....	29
5.4.9. GPS Status	29
5.4.10. Language	29
5.4.11. Set RA Guiding (CEM25EC Only).....	29
5.5. Electric Focuser	29
5.6. PEC Option.....	30
5.6.1. PEC Playback	30
5.6.2. Record PEC	30
5.6.3. PEC Data Integrity	30
5.7. Edit User Objects.....	30
5.7.1. Enter a New Comet	30
5.7.2. Enter Other Objects or Observation List.....	31
5.8. Firmware Information	32
5.9. Zero Position	32
5.9.1. Goto Zero Position	32
5.9.2. Set Zero Position	32
6. Maintenance and Servicing	33
6.1. Maintenance	33
6.2. iOptron Customer Service	33
6.3. Product End of Life Disposal Instructions	33
6.4. Battery Replacement and Disposal Instructions.....	33
Appendix A. Technical Specifications	34
Appendix B. Go2Nova® 8408 HC MENU STRUCTURE	35
Appendix C. Firmware Upgrade	37
Appendix D. Computer Control an CEM25 Mount	38
Appendix E. Go2Nova® Star List.....	39
IOPTRON TWO YEAR TELESCOPE, MOUNT, AND CONTROLLER WARRANTY.....	46

1. CEM25 Overview

Welcome to the new CEM25 – The next step up of ZEQ25!

The unique “Z” design of the iOptron® patented Center-Balanced Equatorial Mount, or **CEM**, puts the payload at the center of gravity providing greater natural stability. This means the mount is extremely light compared to its maximum payload – resulting in an observatory class mount that is portable enough for easy transportation and set-up at a remote site. The adjustable counterweight bar prevents the counterweight from getting in the way of the tripod or pier when operating at a low latitude location. Polar aligning is quick and accessible all the time since the polar scope is not blocked by the declination shaft.

The CEM25 uses iOptron’s proprietary controlling technology. The mount is whisper quiet and uses up to 60% less GOTO power consumption than other mounts in the category.

With high precision optical encoder system and advanced control technology, the CEM25EC mount will track a star at a periodic error less than 0.3 arc second rms. A perfect portable mount for unguided astrophotography!

The CEM25 is equipped with the latest advanced GOTONOVA® GOTO technology, making it one of the most powerful and accurate GOTO mounts available. It comes with over 150,000 objects in its database. Plus, the Go2Nova® Hand Controller is intuitive to use with a large 4-line LCD screen to easily set up your telescope and select where you want to go. The CEM25 – a new category of viewing and astrophotography.

Features:

- A new design Center-Balanced equatorial mount for maximum payload and minimum mount weight
- Specialized astrophotography mount ideal for entry-level and intermediate Astro-photographers
- Payload of 27 lbs (12.3 kg) with the mount-only weight of 10.4 lbs (4.7 kg)
- Spring loaded gear system with customer adjustable loading force
- Gear switches on both R.A. and DEC axes for easy balancing when disengaged
- Adjustable counterweight shaft for 0° latitude operation
- **Stepper motor with low power consumption**
- **New electronics and control adapted from CEM60**
- **Position auto recovery after power disrupt**
- **Low periodic error (PE) for a CEM25EC mount (<0.3 arcsec RMS)**
- iOptron AccuAlign™ calibrated polar scope with dark-field illumination and easy polar alignment procedure, allowing for fast and accurate polar alignment
- Polar alignment routine for those who can’t see the Pole Star
- Go2Nova® 8408 controller with Advanced GOTONOVA® GOTO Technology
- Integrated ST-4 autoguiding port
- Built-in 32-channel Global Positioning System (GPS)
- Serial port for firmware upgrade and computer control
- Spring loaded Vixen-style saddle
- 1.5” or 2” inch heavy-duty stainless steel tripod
- Die-cast metal tripod spreader with accessory tray
- Optional hard case for mount available (#7180)
- Optional 5.5” or 8” Z-MiniPier extension (#8035 or #8035-8)
- Optional PowerWeight™ rechargeable battery pack (#8128)

- Optional StarFi WiFi adapter (#8434) for full function control via SmartPhone/Tablet/Computer



WARNING: To avoid gear slippage, DO NOT rock the counterweight shaft rigorously. Make sure the Tension Adjuster is set properly. Worm system damage due to user operation error will not be covered by warranty.

The Tension Adjusters are used as the last step to lock, and the first step to release the gears. When disengaging the gear system, release the Tension Adjuster first. Then turn the Gear Switch to OPEN position. When engaging the gear system, turn the Gear Switch to LOCK position first. Then tighten the Tension Adjuster.

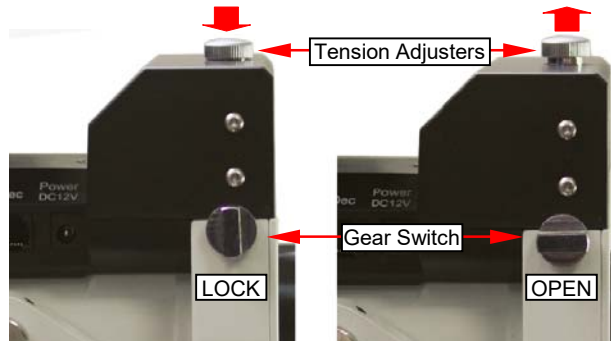

WARNING: Never disengage Gear Switches without holding the mount firmly! Personal injury and/or equipment damage may happen.

If the mount motor has “grinding” sound (which is not harmful) while slewing, the Tension Adjuster is too tight. Release 1/8 to 1/4 turn and check it again. If there is excess play in either RA or DEC axis, or even the gear is skipping, the gear and worm is not meshed properly. Turn the Tension Adjuster more clockwise. You may need to readjust the Tension Adjuster for different payload.

2. CEM25 Terms

2.1. Parts List¹

There are two shipping boxes for a regular tripod version. One box contains a CEM25/CEM25EC mount, hand controller, one 10.4 lbs (4.7kg) counterweight, counterweight shaft, tripod spreader and accessories. The other box contains a tripod.

- iOptron® CEM25/CEM25EC telescope mount (with built-in GPS)
- Go2Nova® 8408 Hand Controller
- One 10.4lbs (4.7 kg) counterweight
- Counterweight shaft
- Dark field illuminating LED cable
- AC adapter (100V-240V)
- Controller Cable X 2 (one long coiled cable and one short straight cable, straight wired 6P6C)
- Serial cable (RS232 to RJ9)
- Short latitude adjustment knob
- 1.5-inch Tripod (#7100) or 2-inch Tripod (#7102)
- Tripod spreader

OPTIONAL PARTS

- Optional hard case (#7180)
- Optional PowerWeight™ rechargeable battery pack (#8128)
- Optional StarFi wireless adapter (#8434)
- Optional 5.5" and 8" Z-MiniPier (#8035/#8035-8)

ONLINE CONTENTS (*click under "Support" menu*) www.iOptron.com

- Quick Start Guide
- This manual
- Tips for set up
- Hand controller and mount firmware upgrades (check online for latest version)
- ASCOM driver
- Reviews and feedback from other customers
- Accessories

¹ US market only. Actual contents may vary.

2.2. Assembly Terms

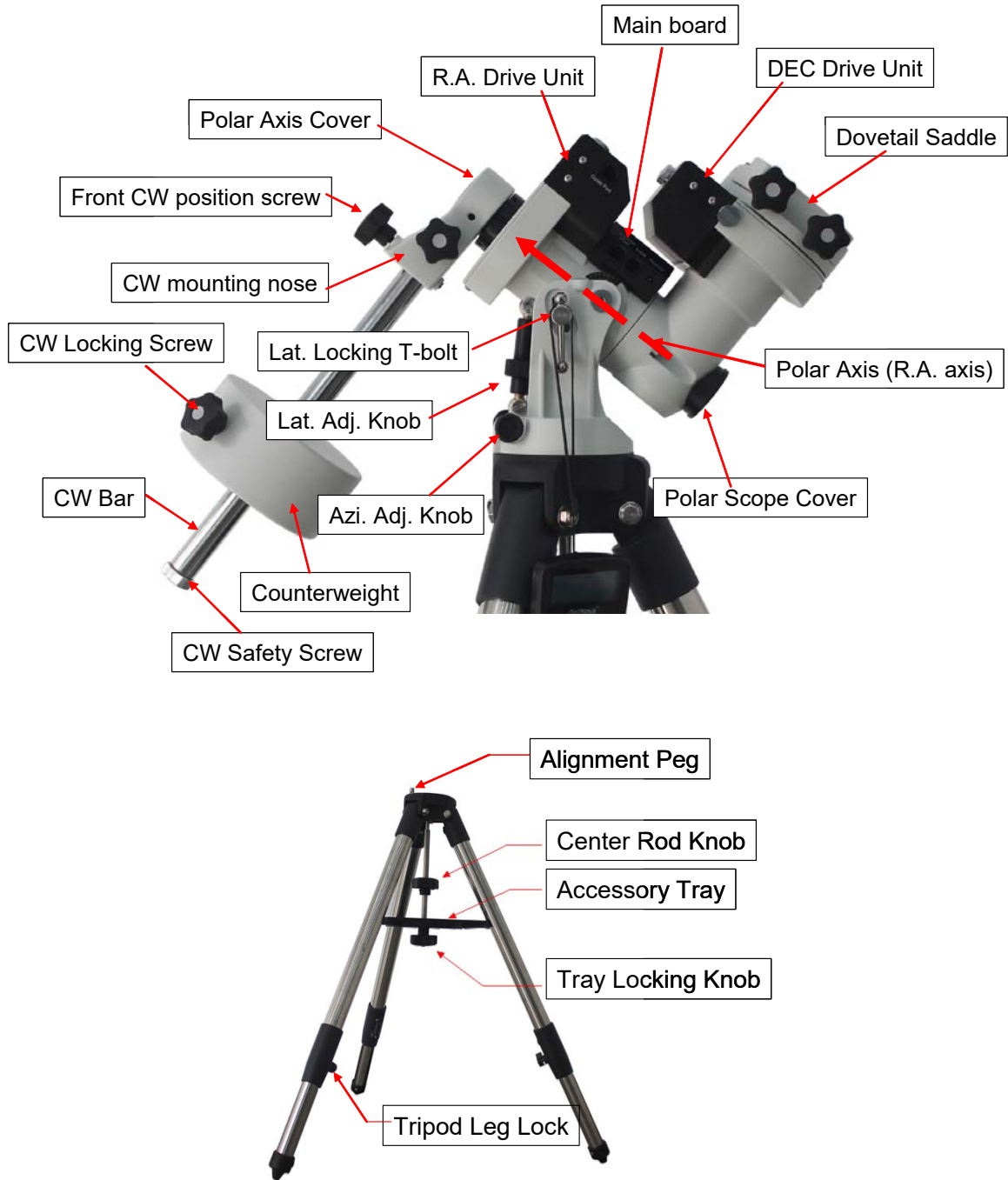

Figure 1. CEM25 assembly terms (mount and tripod)

2.3. CEM25 Ports

Ports on the mount

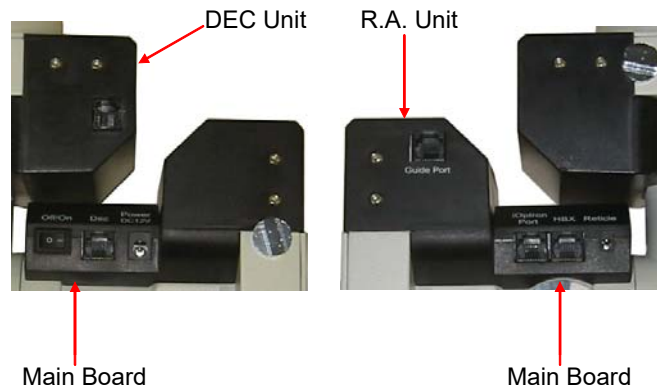

Figure 2. Ports on a CEM25 mount

On main control board:

- OFF/ON Switch: Power switch
- Dec: For connecting to DEC drive unit
- Power DC 12V: DC power plug (2.1mmX5.5mm, center positive)
- iOptron Port: For connecting to other iOptron accessories, such as a laser pointer or a planetary dome control. **DO NOT plug guiding camera cable into it or the camera will be damaged.**
- HBX (Hand Box): For connecting to an 8408 Hand Controller
- Reticle: Power supply for the polar scope dark field illumination LED, or illuminated eyepiece

On RA unit:

Guide Port: Autoguiding port for guiding cameras

On DEC unit:

The only port on the DEC unit is used to connect to the Dec port on main control board

2.4. Go2Nova[®] 8408 Hand Controller



Figure 3. Go2Nova[®] 8408 hand controller

The Go2Nova[®] 8408 hand controller (HC) shown in Figure 3 is the standard controllers that used for a CEM25 mount. It has a 4 line, 21 character large LCD screen, function keys, direction keys and number keys on the front; a and a HBX port (6-pin) and a serial port (4-pin) at the bottom.

2.4.1. Key Description

- MENU Key: Press “MENU” to enter the Main Menu.
- BACK Key: Move back to the previous screen, or end/cancel current operation, such as slewing.
- ENTER Key: Confirm an input, go to the next menu, select a choice, or slew the telescope to a selected object.
- Arrow (▲▼◀▶) Keys: The arrow keys are used to control the movement of DEC and R.A. axes. Press and hold ▲(DEC+),▼(DEC-) buttons to move a telescope along the DEC direction, ◀(R.A.+), ▶(R.A.-) to move a telescope along the RA direction. They are also used to browse the menu or move the cursor while in the menu. **Holding an arrow key for a fast scrolling.**
- Number Keys: Input numerical values. Also used to adjust slewing speeds (1: 1X; 2: 2X; 3: 8X; 4: 16X; 5: 64X; 6: 128X; 7: 256X; 8: 512X; 9: MAX)
- ? Key: **Identify and display nearby bright stars or objects where the telescope points to.**
- 0 Key: Stop the mount during GOTO. **Also toggling between start and stop tracking.**
- HBX (Handbox) port: connect the HC to a CEM25 mount using a 6 pin 4 wire (6P4C) RJ11 plug.
- Serial port: connect the HC to a Computer via a RS232 to 4 pin 4 wire (4P4C) RJ9 cable (iOptron item# [8412](#)) for firmware upgrade and computer controller. The pin out of the serial port is shown in Figure 4.

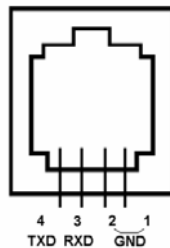

Figure 4. Serial port pin out on an 8408 hand controller

2.4.2. The LCD Screen

The 8408 HC has a large 4-line, 21-character per line LCD screen. The user interface is simple and easy to learn. When the mount first turned on, an initial information screen will be displayed as shown in **Figure 5**, after company logo displayed. It displays the Zero Position, current date and time.

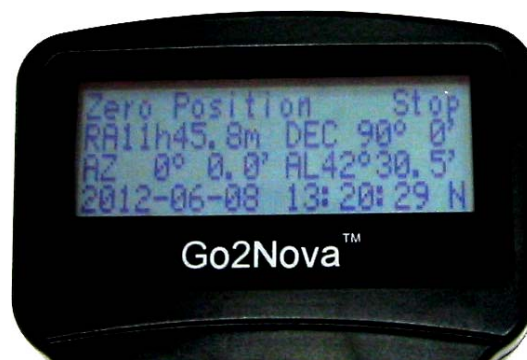

Figure 5. 8408 Initial Information Screen

The LCD screen will switch to the information screen, as indicated in **Figure 6**, with pressing any button.



Figure 6. 8408 HC LCD Information Screen

1. Target Name/Mount Position: displays the name of the target that telescope is currently pointed to or the current mount position.
 - An object name, such as “Mercury” or “Andromeda Galaxy”: Name of the Star or celestial object that the mount is currently slewing to, GOTO or tracking;
 - User Position: The mount is point to a user defined position, which could be a real sky object or just simply due to press an arrow key.
2. Magnitude: the magnitude of the current celestial object
3. Right Ascension: Right Ascension of the telescope, or R.A.
4. Declination: Declination of the telescope, or DEC.
5. Azimuth: Azimuth of the telescope (north is 0°, east 90°, south 180°, and west 270°).
6. Altitude: Altitude of the telescope (degrees vertical from the local horizon - zenith is 90°).
7. Mount Status: Display current operation status of the mount.
 - Stop: mount is not moving;
 - Slew: mount is moving with an arrow key is pressed;
 - GoTo: mount is slewing to a celestial object using “Select and Slew”;
8. Slew speed: It has 9 speeds: 1X, 2X, 8X, 16X, 64X, 128X, 256X, 512X, MAX(1440X, or 6°/sec).
9. Current Time: display local time in a format of HH:MM:SS.

2.5. Check the Battery



The hand controller has a real time clock (RTC) which should display the correct time every time the mount is turned on. If the time is incorrect, please check the battery inside the hand controller and replace it if needed. The battery is a 3V, CR1220 button battery.

2.6. Bench Testing the Mount

The counterweight shaft is designed to counter balance the mount’s own weight. It is recommended that the CW shaft is installed when testing the mount’s function.

NEVER operate the mount with only the counterweight or OTA on it, as shown in the image in Figure 7. It may cause gear slippery and cause the worm and gear damage.



Figure 7. **Do not** operate the mount with an unbalanced load

3. CEM25 Mount Assembly

3.1. Introduction

You have just purchased a telescope mount that is capable of taking you to a new level of astronomy. No matter which telescope or optical tube assembly (OTA) you select to install on the mount, the overall performance will be greatly enhanced. In order for you to get the optimum performance from the mount and OTA combination, you must assemble and adjust the mount correctly. The following fundamentals of telescope mounts are included to help you understand the big picture before you get into the specific details of the CEM25 mount.

Telescope mounts are either equatorial mounts or altitude-azimuth (Alt-Az) mounts. Both types of mounts rotate the OTA around two perpendicular axes to point to a desired object in the night sky. An equatorial mount has the right ascension (R.A.) axis aligned with the celestial North Pole (CNP), or celestial South Pole (CSP) in southern hemisphere, to provide rotation matching the celestial sphere rotation around the Earth and the declination axis (DEC) to provide elevation relative to the celestial equator. Since all celestial objects appear to rotate around the CNP, the R.A. axis allows the OTA to rotate with the celestial sphere and provide accurate tracking for visual observations and astrophotography. R.A. is the celestial equivalent of longitude. Like longitude, R.A. measures an angle that increases toward the East as measured from a zero reference point on the celestial equator. An Alt-Az mount has a horizontal axis to provide vertical (altitude) OTA movement from the local horizon and a vertical axis to provide horizontal (azimuth) OTA movement, similar to compass headings. An Alt-Az mount can provide tracking that is good enough for visual observing and short exposure photos, but not good enough for serious astrophotography. Alt-Az mounts require star alignments for the OTA to track stars and they do not have adjustment components on the mount. Equatorial mounts require alignment of the mount components as well as star alignments for accurate OTA tracking.

In order to provide the required Polar Axis alignment, equatorial mounts use a combination of both mount types described above. The adjustable part of the mount moves in the Alt-Az mode in order to align the R.A. axis, also known as the mount's Polar Axis, with the CNP. These Polar Axis adjustments do not involve any rotations of the OTA about the R.A. or DEC axes and can be performed without the OTA installed. The first step is to make an approximate azimuth alignment of the Polar Axis by aligning the specified tripod leg or reference point toward True North using a compass for reference (you must allow for the variation between True and Magnetic North at your location). Precise horizontal alignment of the Polar Axis is accomplished with azimuth adjustments on the mount. The second step is to adjust the Polar Axis vertically (altitude) above the North horizon by setting the observer's latitude on the provided latitude scale. This procedure is based on the fundamental geometry of the Earth's coordinate system in conjunction with the concept of the celestial sphere. You can verify this by visualizing yourself at the North Pole (latitude $N90^\circ$) and Polaris will be 90° from the horizon, or directly overhead. These steps will place the Polar Axis very close to the CNP. Both of the above adjustments can be enhanced by the use of an opening along the R.A. axis that allows direct viewing of the North Star and the use of a polar scope to view through this opening. If you are going to get the most out of your equatorial mount it is essential to understand the concept of the Polar Axis and how the equatorial mount helps you establish and maintain a true Polar Axis alignment. Now, you are ready to perform star alignments using the equatorial mount's electronic controller and enjoy the night sky.

The CEM25 mount is a next-generation equatorial mount that provides the precision alignment capabilities required for today's complete astronomy solution. The following sections of this manual provide the detailed steps required to successfully set up and operate the CEM25 mount.

3.2. CEM25 Mount Assembly

NOTE: The CEM25 mount is a precision astronomical instrument. It is highly recommended that you read the entire manual and become familiar with the nomenclature and function of all components before starting the assembly.

 **WARNING:** To avoid gear slippage, **DO NOT** rock the counterweight shaft rigorously and make sure the Tension Adjuster is set properly. Worm system damage due to user operation error will not be covered by warranty.

 **WARNING:** The new Gear Switch will allow you to have most precise weight balance. This also means the mount or OTA will swing **FREELY** when the Gear Switch is disengaged. Always hold the OTA or mount when release Gear Switch or adjust gear tension.

NOTE: The mount is shipped with latitude setting at high range (35° ~ 60°). If your site latitude is lower than 35°, please switch the latitude range before using it.

STEP 1. Remove the mount from the package:

The mount is shipped with R.A. gear disengaged to protect the worm/gear system. Carefully remove the mount from the shipping box and familiarize yourself with the components shown in Figure 1. Turn the Gear Switch 90° to lock the R.A. gear system. Make sure DEC is locked as well.

STEP 2. Select Mount Latitude Range

The mount is by default shipped with the **Long Latitude Adjustment Knob** installed (for 35-60°). At lower latitudes of 0-35°, the **Short Latitude Adj. Knob** needs to be used. To change this knob:

- (1) Remove the Latitude Locking T-bolts on both sides (do not lose the 4 washers).
- (2) Unscrew bottom post Locking Screw to free the Brass Bottom Latitude Adj. Post and remove the Latitude Adj. Knob (Figure 8a).
- (3) **Evenly** thread in the **Short** Latitude Adj. Knob to the brass Top and Bottom Latitude Adjustment Posts.
- (4) Reinstall and tighten bottom Locking Screw.
- (5) Lastly, with all 4 washers properly placed, insert and tighten Latitude Locking T-bolts into the upper threaded holes (Figure 8b).

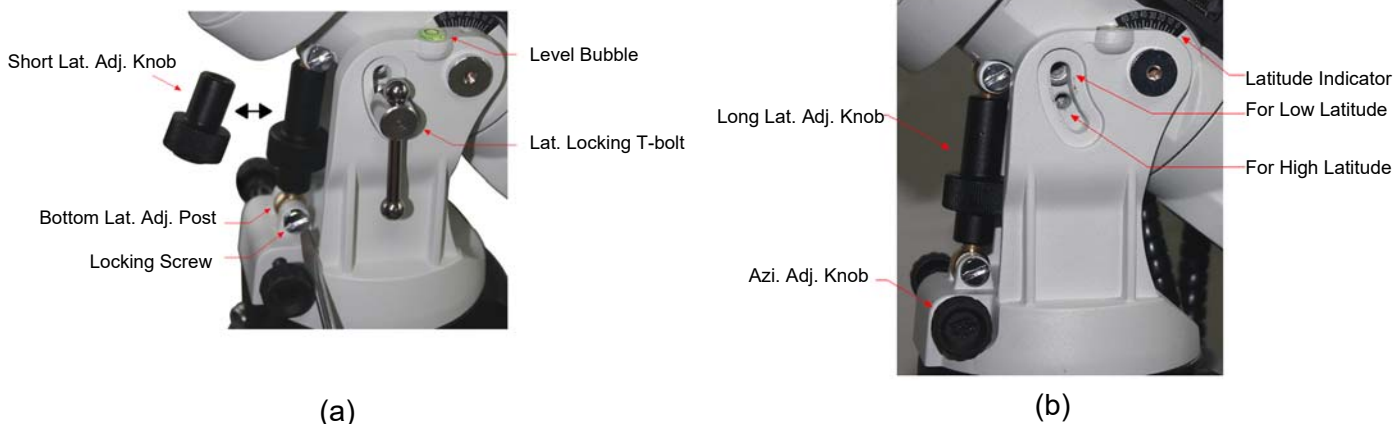

Figure 8. Switching latitude adjustment knob

STEP 3. Tripod Setup

Expand the tripod legs. Adjust the tripod height by unlocking and re-locking the Tripod Leg Locks to desired height. Position the tripod so that the Alignment Peg faces north, if you are located at northern hemisphere. If you are located in southern half, face the Alignment Peg south. Thread the tripod center rod into the tripod head and install the Accessory Tray and tread the Tray Locking Knob onto it. Do not fully tighten the Tray Locking Knob.

There are two threaded holes on the tripod head for alignment peg installation. The Alignment Peg may be moved to the opposite position shall the mount hit the tripod leg when used at a high latitude.



Figure 9. Set up tripod

STEP 4. Attach the CEM25 Mount

Back out both Azimuth Adj. Knobs to allow enough clearance inside the chamber. Position the mount on the tripod head with the Alignment Peg in between the two Azimuth Adj. Knobs. Thread the Center Rod into mount to secure it with tripod. Tighten the Tray Locking Knob to fully spread the tripod legs. Adjust the tripod legs to level the mount using the Level Bubble.

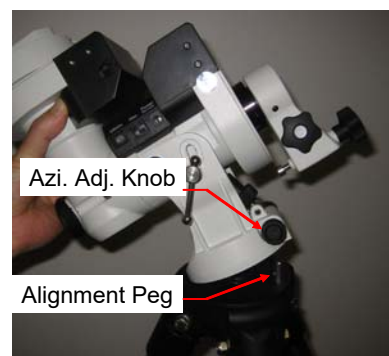

Figure 10. Attach a mount

STEP 5. Adjust Latitude

This step requires you to know the latitude of your current location. This can be found from your 8408 hand controller after the embedded GPS receives the signal from the satellites. It also can be easily found on the Internet, with your GPS navigator or a GPS capable cell phone. You will have to change this latitude setting every time you significantly change your night sky viewing location. This setting directly affects the mount's tracking and GOTO accuracy.

Slightly loosen the Latitude Locking T-bolts. Turn Latitude Adjust Knob to adjust the latitude until the arrow points to your current latitude on the Latitude Indicator (see Figure 8b). Relock the Latitude Locking T-bolts. At this point, with the mount leveled and pointed north, and the latitude set, the Polar Axis (R.A. axis) should be pointing very close to the NCP and Polaris. This alignment accuracy will be sufficient for visual tracking and short duration piggy-back (camera mounted on top of the OTA) astrophotography.

STEP 6. Install Counterweight (CW) Shaft

- (1) Remove CW Shaft Locking Screw from the CW Mounting Nose.
- (2) Insert CW shaft into the CW Mounting Nose as indicated in Figure 11b.
- (3) Lock it using CW Shaft Locking Screw from the other side of the CW Mounting Nose. Tighten the Front CW Positioning Screw which is located in front of the CW Mounting Nose.

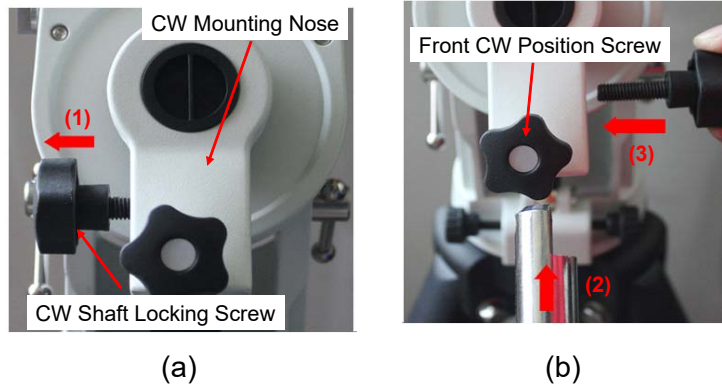

Figure 11. Install counterweight shaft

If the latitude of the observation location is lower than 10° , thread in the Rear CW Position Screw (a hex head set screw) before tightening the Front CW Positioning Screw to avoid CW hit tripod legs. Then tighten the Front CW Positioning Screw.

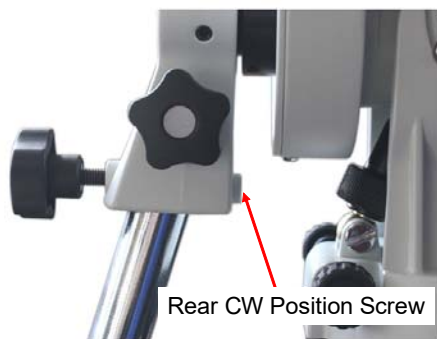

Figure 12. Tilt counterweight shaft for low altitude

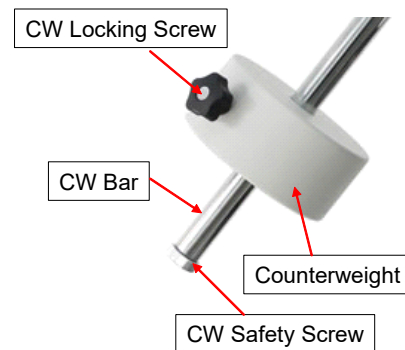

Figure 13. Install counterweight

STEP 7. Install Counterweight

Before installing the counterweight, make sure that both R.A. and DEC Gear Switches are fully engaged to avoid sudden mount movements which could cause injury and/or damage the mount gear system and your equipment.

Make sure the mount is at the zero position (i.e. counterweight shaft is pointing to the ground) when installing the counterweight.

Turn the R.A. gear switch to OPEN position to set the R.A. axis free before loading the CW. Remove CW Safety Cap at the end of CW Shaft. With the wider opening towards the shaft end, guide CW through the shaft. Use the CW Locking Screw to hold the CW in place. Place Safety Cap back onto the shaft. Turn the R.A. gear switch to CLOSE position again.

A CEM25 mount comes with a 10.4 lbs (4.7kg) counterweight. It should be able to balance a total payload of about 13 lbs (6kg) for a 8" diameter telescope. An optional CW or extension bar is needed for a heavier payload or a larger diameter Telescope.

STEP 8. Attach and Balance an OTA

After attaching an OTA and accessories to the mount, the CEM25 mount must be balanced in both R.A. and DEC axes to ensure minimum stress on the mount (such as gears and motors inside). **Make sure the OTA is properly secured.**

CAUTION: The telescope may swing freely when the R.A. or DEC Gear Switch is released. Always hold on to the OTA before you release the gear switch to prevent it from swinging. It can cause personal injury or damage to the equipment.

Release Tension Adjuster by turning it counterclockwise. Turn Gear Switch knob 90 degree to OPEN position to disengage the worm from the worm wheel.

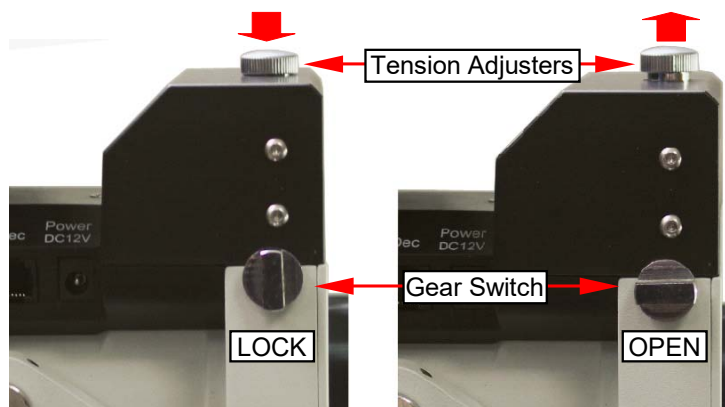

Figure 14. Gear Switch operation

Rotate the DEC axis to horizontal position. Move the OTA position to balance the mount along DEC axis (Figure 15a). Adjust the CW position to balance the mount in R.A. axis (Figure 15b).

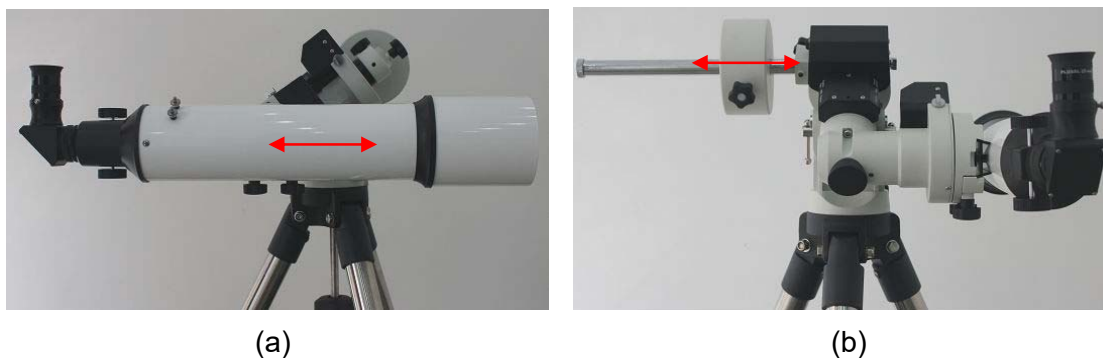

Figure 15. Balance along R.A. axis (a) and DEC axis (b)

CAUTION: The balance process MUST be done with Gear Switch at OPEN position! Otherwise it might damage the worm system.

Return the mount to Zero Position after balance, i.e. the CW shaft points to ground and telescope is at the highest position.

Turn Gear Switch Knob by 90° to LOCK position to re-engage the worm to the worm wheel. Retighten the Tension Adjuster as the last step to lock the gear.

STEP 9. Connect Cables

Connect DEC unit to the main control unit with a short, straight RJ11 cable. Connect the Go2Nova® 8408 hand controller to the HC port on the main unit. Plug 12V DC power supply into the POWER socket. The power indicator on the main unit will be on when the power switch is turned on.

STEP 10. Setup Hand Controller

The CEM25 is equipped with a GPS receiver, which will receive the time, longitude and latitude information from satellites after the link is established. However, there are still some parameters need to be entered to reflect your location, such as time zone info and daylight saving time. The information will be stored inside the hand controller memory along with longitude and latitude coordinates until they need to be changed.

A clear sky and open space outside is needed for the GPS to establish its link with the satellites. The GPS is installed on top of the R.A. motor control board. If it has difficulty to receive the GPS signal with the telescope installed, you may turn the mount head 90° to the side of the mount to clear the space on top of the main board. **Do not leave the hand controller on GPS Status submenu waiting for GPS ON tuning into GPS OK.**



Figure 16. Rotate mount head 90° to clear the space for GPS receiver

To set up the controller, turn the mount power ON. Press **MENU**=> **“Settings”**:

```
Select and Slew
Sync. to Target
Alignment
Settings
```

Press **ENTER** and select **“Set Time and Site”**

```
Set Time and Site
Set Beep
Set Display
Set Guiding Rate
```

Press **ENTER**. A time and site information screen will be displayed:

```
2013-04-01 12:01:36
UTC -300 Minute(s)
W071d08m50s      DST: N
N42d30m32s      Northern
```

Daylight Saving Time

Set Local Time

The time will be updated automatically when the GPS receiver has established its link with the GPS satellites. In the event that the GPS module is unable to establish a link to the satellites, local time can be entered manually. Use the ◀ or ▶ key to move the cursor █ and use the number keys to change the numbers. Use the ▲ or ▼ button to toggle between “Y” and “N” for Daylight Saving Time, or “+” and “-” for UTC (Coordinated Universal Time) setting. Hold the arrow key to fast forward or rewind the cursor.

In order to make the Hand Controller reflect your correct local time, **time zone information has to be entered**. Press the ◀ or ▶ key, move the cursor to the third line **“UTC -300 Minute(s)”** to set the time zone information (add or subtract 60 minutes per time zone). For example:

- Boston is “UTC -300 minutes”
- Los Angeles is “UTC -480 minutes”
- Rome is “UTC +60 minutes”
- Beijing is “UTC +480 minutes”
- Sydney is “UTC +600 minutes”

All the time zones in North America are “UTC -”, as shown in the following table, so ensure the display shows **“UTC -”** instead of **“UTC +”** if in North or South America.

Time Zone	Hawaii	Alaska	Pacific	Mountain	Central	Eastern
Hour behind UT	-10	-9	-8	-7	-6	-5
Enter UTC	-600	-540	-480	-420	-360	-300

To adjust minutes, move the cursor to each digit and use the number keys to input the number directly. Use ▲ or ▼ key to toggle between “+” and “-”. When the time information entered is correct, press ENTER and go back to the previous screen. **Note that fractional time zones can be entered.**

Do not manually add or subtract an hour from displayed time to reflect Daylight Saving Time (DST). Only select “Y” after DST begins.

For other parts of the world you can find your “time zone” information from internet.

Set Observation Site Coordinate

The third and fourth lines display the longitude and latitude coordinates, respectively. The longitude and latitude coordinates will be automatically updated when the GPS picks up satellite signals. “W/E” means western/eastern hemisphere; “N/S” means northern/southern hemisphere; “d” means degree; “m” means minute; and “s” means second.

If, for any reason, your GPS can’t pick up a signal, you can manually enter the GPS coordinates. Press ◀ or ▶ key to move the cursor and using ▲ or ▼ key to toggle between “W” and “E”, “N” and “S”, using number key to change the numbers. It is always a good idea to do your home work to get the GPS coordinates before traveling to a new observation site.

The site coordinates information can be found from your smart phone, GPS receiver or via the internet. Site information in decimal format can be converted into d:m:s format by multiplying the decimal numbers by 60. For example, N47.53 can be changed to N47°31’48”:
 $47.53^\circ = 47^\circ + 0.53^\circ$,
 $0.53^\circ = 0.53 \times 60' = 31.8'$, $0.8' = 0.8 \times 60'' = 48''$.
Therefore, $47.53^\circ = 47^\circ 31' 48''$ or 47d31m48s.

Select N/S Hemisphere

If the polar axis is aligned to the North Celestial Pole, then set the mount to Northern Hemisphere. If the polar axis is pointing to the South Celestial Pole, set the mount to Southern Hemisphere. Press the ◀ or ▶ key to move the cursor and use the ▲ or ▼ key to toggle between “Northern Hemisphere” and “Southern Hemisphere”.

As an example, select Northern Hemisphere if you are located in US and press **ENTER** to go back to the main menu.

The time and site information will be stored inside the hand controller’s memory chip. If you are not traveling to another observation site, they do not need to be changed.

Check the Hand Controller Battery



The hand controller has a real time clock which should display the correct time every time the mount is turned on. If the time is off too much, please check the battery inside the hand controller and replace it if required. The battery is a 3V, CR1220 button battery.

STEP 11. Polar Alignment

One of CEM25’s unique features is that the polar scope can be accessed at anytime. It will not be blocked by DEC axle as in a German equatorial mount. This makes it possible to adjust the polar alignment during the tracking.

In order for an equatorial mount to track properly, it has to be accurately polar aligned.

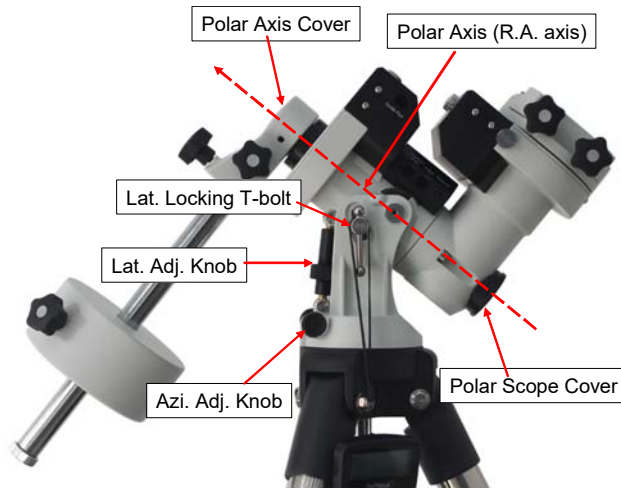

Figure 17. Polar alignment

The CEM25 mount equipped with an iOptron's AccuAlign™ polar scope. You can do a fast and accurate polar axis alignment with iOptron's **Quick Polar Alignment** procedure.

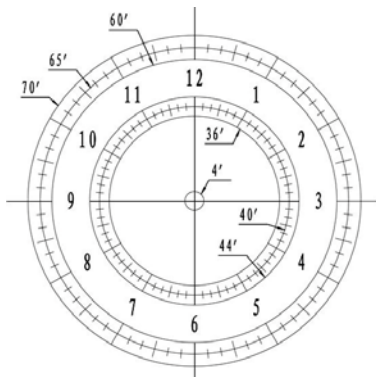

Figure 18. Polar Scope



Figure 19. Polar Scope LED

As indicated in Figure 18, the Polar Scope reticle has been divided into 12 hours along the angular direction with 10 minute ticks. There are 6 concentric circles in 2 groups of 3 marked from 36' to 44' and 60' to 70', respectively. The 36' to 44' concentric circles are used for polar alignment in the Northern Hemisphere using Polaris, while the 60' to 70' circles are used for polar alignment in Southern Hemisphere using Sigma Octantis.

Quick Polar Alignment

- (1) Level the CEM25 mount. Make sure the telescope is parallel to the pole axis (R.A. axis) of the mount. If a finder scope is used, adjust it to be parallel to the telescope optical axis. You may check the parallelness during daytime with a distance object.
- (2) Take off the Polar Axis Cover and Polar Scope Cover. Connect polar scope LED cable between Reticle plug located on the main unit and the LED socket at the bottom of the DEC axle, as shown in Figure 19. Turn on the mount power by pressing the **On/Off** switch on the main unit. The light intensity can be adjusted using the HC via **MENU=>"Settings"=>"Set Eyepiece Light"** function under **"Set Up Controller"** menu.
- (3) Make sure that the time and site information of the hand controller is correct. Press the **MENU =>"Alignment"=>"Pole Star Position"** to display the current Polaris position. For example, on June 22, 2014, 20:19:42 in Boston, US (alt N42°30'32" and long W71°08'50"), UTC -300 minutes, DST:Y, the Polaris Position is 0h45.8m and 40.4m, as shown in Figure 20a.

- (4) Look through the polar scope to find the Polaris. Using Azimuth Adjustment Knob and Latitude Adjustment Knob to adjust the mount in altitude and azimuth directions and put the Polaris in the same position on the Polar Scope Dial as indicated on the HC LCD. In this case, the Polaris will be located at a radius of 40.4' and an angle of 0 hour 45.8 minute, as shown in Figure 20b.

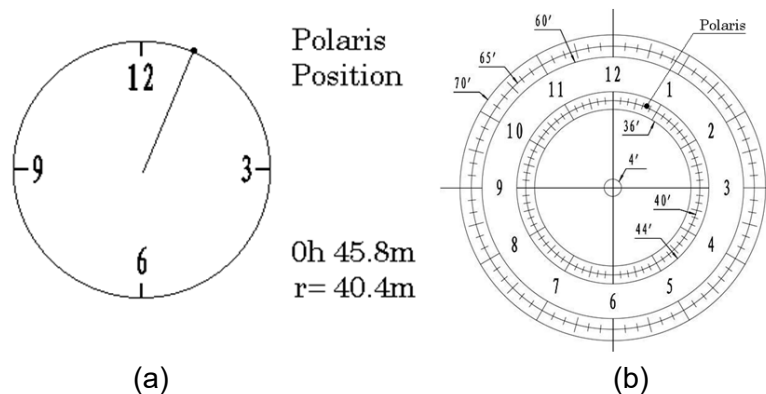

Figure 20. Polaris Position shown on HC (a) and where to put on polar scope dial (b)

NOTE: If you are located in southern hemisphere, Sigma Octantis will be chosen for Polar Alignment. For example, on May 20, 2010, 20:00:00 in Sydney, Australia (Lat S33°51'36" and Long E151°12'40"), 600 min ahead of UT, the Sigma Octantis Position is 1hr21.8m and 64.4m.

BrightStar Polar Alignment/Polar Iterate Align

BrightStar Polar Alignment allows you to polar align the mount even if you cannot view the Celestial Pole.

- (1) Level the CEM25 mount and set it at Zero Position. Make sure the telescope is parallel to the pole axis (R.A. axis) of the mount. If a finder scope is used, adjust it to be parallel to the telescope optical axis. Turn the mount power on. Set correct R.A. and DEC backlash numbers. An eyepiece with cross hairs is needed.
- (2) Pressing **MENU=>"Alignment"=>"Polar Iterate Align"**. The HC will display the azimuth and altitude position of several bright stars near meridian. Select one that is visible with high altitude as Alignment Star A. Follow the HC instruction to move the Star A to the center of the eyepiece with the combination of Latitude Adjustment Knob and "◀" or "▶" button. Press **ENTER** to confirm. Next, select a bright star that is close to the horizon as the Alignment Star B. Center it using the Azimuth Adjustment Knob and "◀" or "▶" button (The "▲" and "▼" buttons are not used here). Press **ENTER** to confirm.
- (3) The telescope will now slew back to Star A to repeat above steps. The iteration can be stopped when it is determined that the alignment error is at the minimum. Press **BACK** button to exit alignment procedure.

NOTE: The movement of the alignment star in your eyepiece may not be perpendicular but crossed, depends on its location in the sky.

STEP 11. Return Mount to Zero Position

After polar alignment and balancing OTA, return the mount to Zero Position, as shown in Figure 21. The Zero Position is the position with the CW shaft pointing toward the ground, OTA at the highest position with its axis parallel to the polar axis and the OTA pointing to the Celestial Pole.

You need to set the Zero Position when the mount is used first time, or firmware upgrade is performed. To set the mount to Zero Position, press **MENU=>"Zero Position"=>"Set Zero Position"**.

Release the Gear Switch to manually return the mount to Zero Position, or use the hand controller to slew the mount to Zero Position. Press **ENTER** to confirm the zero position.

Check the Zero Position by using **MENU=>"Zero Position"=>"Goto Zero Position"** before each session.



Figure 21. Zero position

4. Getting Started

In order to experience the full GOTO capability of GOTO^{NOVA}® technology it is very important to set up the mount correctly before observation.

4.1. Setup the Mount and Polar Alignment

Assemble your CEM25 mount according to Section 3.2. Turn the mount power switch on. When the GPS receiver is connected to satellites, LCD will display GPS OK. The mount will have correct time and site information. You can also enter them manually as described before. Mount an OTA and accessories, and carefully balance the mount around the polar axis. Polar align you mount using either **Quick Polar Alignment** or **BrightStar Polar Alignment Procedure**.

Always check if the mount is at the Zero Position when the mount is powered on, i.e. with the counterweight shaft pointing to ground, OTA at the highest position with its axis parallel to the polar axis and the telescope pointing to the Celestial Pole. Press **MENU => “Zero Position” => “Goto Zero Position”** to check it. If the mount is not at the Zero Position, press **MENU => “Zero Position” => “Set Zero Position.”** Release the Gear Switch to manually return the mount to Zero Position, or use the hand controller to slew the mount to Zero Position. Press **ENTER** to confirm the zero position..

4.2. Manual Operation of the Mount

You may observe astronomical objects using the arrow keys of a Go2Nova[®] hand controller.

Flip the I/O switch on the telescope mount to turn on the mount. Use **▶, ◀, ▼** or **▲** buttons to point the telescope to the desired object. Use the number keys to change the slewing speed. Then press **0** button to start tracking. Press **0** button again to stop the tracking.

4.3. Initial Star Alignment

Perform a simple one star alignment/synchronization after set up the hand controller to correct any pointing discrepancy of the Zero Position and to improve the GOTO accuracy.

To perform “**One Star Align**,” press **MENU=>“Alignment”=>“One Star Align”=>ENTER**. The screen will display a list of bright objects for you to select from. Select an object using **▲** or **▼** key. Then press **ENTER**. After the mount slews to the target, use the arrow keys to center it in your eyepiece. Then press **ENTER**. (More align details in 5.4)

An alternate way is to perform “**Sync to Target**.” Press **MENU=>“Select and Slew”=>ENTER**. Browse over the catalogs and select an object. Press **ENTER**. After the mount slews to the star, press **MENU=>“Sync. To Target”**, follow the on-screen instruction to center the star and press **ENTER**. You may need to use the number keys to change the slewing speed to make the centering procedure easier.

4.4. Go to the Moon and Other Stars

After performing these set-ups the mount is ready to GOTO and track objects. One of the most common objects is the Moon.

To slew to the Moon press **MENU=>“Select and Slew”=>“Solar System”=>Moon=>ENTER**. The telescope will automatically slew to the Moon and lock on it. It will automatically begin to track once it locks on. If the Moon is not centered in your eyepiece, use the arrow keys to center the Moon. You may use “**Sync to Target**” to improve the tracking.

You may also select other bright celestial objects to start with, such as Jupiter or Saturn.

4.5. Star Identifying Function

The 8408 hand controller has a star identifying function. After **Polar Alignment** and **Set Up Time and Site**, slew the telescope to an bright star, manually or using GOTO. Press ? button to identify the star name telescope is pointing to, as well as nearby bright stars if there are any.

4.6. Gear Tension Adjustment

Set both Gear Switches to LOCK positions after balancing the mount. Fully screw in the Tension Adjuster. If the mount motor has “grinding” sound (which is not harmful) while slewing, the Tension Adjuster is too tight. Release 1/8 to 1/4 turn and check it again. If there is excess play in either RA or DEC axis, or even the gear is skipping, the gear and worm is not meshed properly. Turn the Tension Adjuster more clockwise. You may need to readjust the Tension Adjuster for different payload.

4.7. GOTO and Tracking Position Memorization

The CEM25 mount can memorize its R.A. and DEC positions if the mount loses its power by accident, even during high speed slewing. Just do a **Select and Slew** to the same star when the power is lost after the power is back. The mount will continue to track the star.

4.8. Turn Off the Mount

When you have finished your observation, just simply turn the mount power off and disassemble the mount and tripod. If the mount is set up on a pier or inside an observatory, you can return the mount to Zero Position. This will ensure that there is no need for you to perform the initial setup again when you power up the mount subsequently, if the mount is not moved. To return the mount to its Zero Position, press the **MENU => “Zero Position” => “Goto Zero Position”** and press **ENTER**. Once the telescope returns to Zero Position turn the power off.

5. Complete Functions of Go2Nova® 8408 Hand Controller

5.1. Slew to an Object

Press **MENU** => “**Select and Slew.**” Select an object that you would like to observe and press the **ENTER** key.

The Go2Nova® 8408 hand controller for CEM25 mount has a database of over 150,000 objects. Use the ► or ◀ buttons to move the cursor. Use the number buttons to enter the number, or the ▼ or ▲ buttons to change the individual number. Hold on a button to fast scroll through the list. The “☉” indicates the object is above the horizon, and a cross mark “☼” means it is below the horizon. In some catalogs those stars below the horizon will not display on the hand controller.

5.1.1. Solar System

There are 9 objects in the Solar system catalog.

5.1.2. Deep Sky Objects

This menu includes objects outside our Solar system such as galaxies, star clusters, quasars, and nebulae.

- Named Objects: consists of 60 deep sky objects with their common names. A list of named deep sky objects is included in Appendix E.
- Messier Catalog: consists of all 110 Messier objects.
- NGC Catalog: consists of 7,840 objects in NGC catalog.
- IC Catalog: consists of 5,386 objects in IC catalog.
- UGC Catalog: consists of 12,921 objects.
- Caldwell Catalog: consists of 109 objects.
- Abell Catalog: consists of 4076 objects.
- Herschel Catalog: consists of 400 objects.

5.1.3. Stars:

- Named Stars: consists of 195 stars with their common names. They are listed alphabetically. A list is included in Appendix E.
- Binary Stars: consists of 210 binary stars. A list is attached in Appendix E.
- Hipparcos Catalog: the new HIP catalog consists of 120,404 records (2008).

5.1.4. Constellations

This catalog consists of 88 modern constellations with their names. They are listed alphabetically. A list is attached in Appendix E.

5.1.5. Comets

This catalog contains 15 comets.

5.1.6. Asteroids

This catalog contains 116 asteroids.

5.1.7. User Objects

It can store up to 60 used entered objects, including comets.

5.1.8. Enter R.A. DEC

Here you can go to a target by entering its R.A. and DEC numbers.

5.2. Sync to Target

This operation will match the telescope's current coordinates to Target Right Ascension and Declination. After slewing to an object, press **MENU** => "**Sync to Target**" => **ENTER**. Follow the screen to perform the sync. Using this function will re-calibrate the computer to the selected object. Multiple syncs can be performed if needed. This operation is most useful to find a faint star or nebula near a bright star.

"**Sync to Target**" will only work after "**Select and Slew**" is performed. You can change the slewing speed to make the centering procedure easier. Simply press a number (1 through 9) to change the speed. The default slew speed is 64X.

"**Sync to Target**" will improve the local goto accuracy around the synced star.

5.3. Alignment

This function is used for aligning the telescope to the celestial pole and to create a sky model to calibrate the mount's GOTO[®] functionality.

The hand controller provides two polar alignment methods. The "**Two Star Polar Align**" is used to refine the polar alignment using the AccuAlign[™] polar scope and **Quick Polar Alignment**. The "**Polar Iterate Align**" uses a set of 2 bright stars for polar alignment providing a viable polar alignment approach for those who can't see the pole.

The system provides three alignment methods to calibrate the mount's GOTO function: "**Solar System Align**", "**One Star Align**", and "**Three Star Align**". The mount has to be at Zero Position before performing any alignment.

5.3.1. Pole Star Position

This function displays the position of the Pole Star for **Quick Polar Alignment** using the iOptron[®] AccuAlign[™] polar scope. In the Northern Hemisphere the position of Polaris is displayed, while in the Southern Hemisphere the position of Sigma Octantis is shown.

5.3.2. One Star Alignment

Press **MENU** => "**Alignment**" => "**One Star Align**". A list of alignment stars that are above the horizon is computed based on your local time and location. With the mount in the Zero Position, use the ▲ and ▼ buttons to select a star and press **ENTER**. Center the target in your eyepiece using the arrow keys. Press **ENTER** when finished. If your mount is set up correctly and polar aligned, one star alignment should be sufficient for good GoTo accuracy. To increase the pointing accuracy over the sky, you may choose to do a three star alignment.

5.3.3. Two Star Polar Align

Two Star Polar Align can improve the accuracy of the mount's polar alignment. Press **MENU** => "**Alignment**" => "**Two Star Polar Align**." A list of alignment stars that are above the horizon is computed based on your local time and location. With the mount at the Zero Position, use the ▲ and ▼ buttons to

select the first alignment star and press **ENTER**. Center the target in your eyepiece using the arrow keys after the mount slews to it. Press **ENTER** when finished. The hand controller will prompt you to choose a second star. After centering the second star, the two-star alignment is finished.

After the two-star alignment, the altitude and azimuth errors will be displayed. This number can be used to fine tune the Quick Polar Alignment.

For example, if the screen shows 7.5" low and 4.3" east, it means that THE MOUNT axis is pointing low and to the east of the Celestial Pole.

5.3.4. Three Star Align

The three-star alignment will further determine the cone error between the OTA and mount axis. The system will use these data to calculate the goto model. If the cone error is big enough, it is suggested to shim the OTA in DEC to minimize it.

Press **MENU** => "**Alignment**" => "**Three Star Align**." A list of alignment stars that are above the horizon is computed based on your local time and location. With the mount at the Zero Position, use the ▲ and ▼ buttons to select the first alignment star and press **ENTER**. Center the target in your eyepiece using the arrow keys. Press **ENTER** when finished. The hand controller will prompt you to choose a second star. Select third star after the mount aligned to the second star.

The system will display the pointing and cone errors after the three star alignment accepted. The system will update the pointing model accordingly.

5.3.5. Polar Iterate Align

This alignment method allows you to polar align the mount even if you cannot view the Celestial Pole. Press the **MENU** => "**Alignment**" => "**Polar Iterate Align**". The HC will display a list of bright alignment stars near the meridian as Alignment Star A. Follow the HC instructions to move Alignment Star A to the center of the eyepiece using a combination of the Latitude Adjustment Knob and the "◀" and "▶" buttons. Press **ENTER** to confirm the settings. Next, select a bright star that is close to the horizon as Alignment Star B. Center it using the Azimuth Adjustment Knobs and the "◀" and "▶" buttons (*the "▲" and "▼" buttons will not function*). Press **ENTER** to confirm the settings.

The telescope will now slew back to Alignment Star A to repeat the above steps. The iteration can be stopped when it is determined that the alignment error has been minimized. Press the **BACK** button to exit the alignment procedure.

NOTE: It is highly recommended to use an eyepiece with illuminated crosshairs for accurate centering.

NOTE: The movement of the alignment star in your eyepiece may not be perpendicular depending on its location in the sky.

5.3.6. Solar System Align

This function uses a planet or the moon as an alignment object. Press **MENU** => "**Alignment**" => "**Solar System Align**" for a list of available alignment objects.

5.3.7. Display Model Error

This will display linear RA error, linear DEC error, polar misalignment, non-perpendicular between OTA and DEC, and non-perpendicular between HA and DEC.

5.3.8. Clear Alignment Data

This will clear all alignment data created during one star, two star or three star alignment process.

5.4. Settings

5.4.1. Set Time and Site

Refer to STEP 10 in Section 3.2.

5.4.2. Set Beep

The Hand Controller allows a user to turn off the beep partially, or even go to a silent mode. To change this setting press **MENU** => "**Settings**" => "**Set Beep**",

```
Set Up Time and Site
Set Beep
Set Display
Set Guiding Rate
```

Select one of three available modes:

"Always On" – a beep will be heard on each button operation or mount movement;

"On but Keyboard" – a beep will be heard only when the mount is slewing to the object or there is a warning message;

"Always Off" – all sounds will be turned off, including the SUN warning message.

5.4.3. Set Display

Press **MENU** => "**Settings**" => "**Set Display**,"

```
Set Up Time and Site
Set Beep
Set Display
Set Guiding Rate
```

Use the arrow keys to adjust LCD display contrast (**LCD contrast**), LCD backlight intensity (**LCD light**), and keypad's backlight intensity (**Key light**).

5.4.4. Set Guiding Rate

This is an advanced function for autoguiding when a guiding camera is utilized either via a Guide Port or using the ASCOM protocol. Before autoguiding, align the polar axis carefully. Select an appropriate guiding speed. The latest firmware allow you to set the R.A. and DEC guiding speed differently. The R.A. guiding speed can be set between $\pm 0.01X$ to $\pm 0.90X$ sidereal rate. The DEC guiding speed can be set between $\pm 0.10X$ to $\pm 0.99X$ sidereal rate. Follow the instructions of your autoguiding software for detailed guiding operation.

The guide port wiring is shown in Figure 22, which has the same pin-out as that from Celestron / Starlight Xpress / Orion Mount / Orion Autoguider/ QHY5 autoguider.

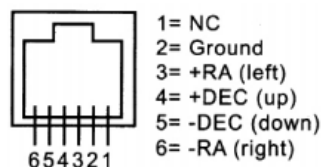

Figure 22. Guide port pin-out

If you have an autoguider which has a pin-out the same as the ST-I from SBIG, such as Meade/ Losmandy/ Takahashi/ Vixen, make sure a proper guiding cable is used. Refer to your guiding camera and guiding software for detailed operation.



WARNING: DO NOT plug your ST-4 guiding camera cable into the iOptron port or HBX port. It may damage the mount or guiding camera electronics.

5.4.5. Set Tracking Rate

You can set up the mount tracking rate by selecting “**Set Tracking Rate**”. Then the user can select “**Sidereal Rate**”, “**Lunar Rate**”, “**Solar Rate**”, “**King Rate**”, and “**User Defined Speed**”. The “User defined speed” can be adjusted from 0.9900X to 1.0100X of sidereal.

The “King Rate”, developed by Edward S. King, corrects the tracking rate of a telescope to account for atmospheric refraction. This is more useful for unguided tracking.

5.4.6. Meridian Treatment

This function tells the mount what to do when it tracks past the meridian. You can tell the mount if it needs a meridian flip and when to do it.

- “**Set Position Limit**” will tell the mount when to stop tracking or to do a meridian flip. The limit can be set at from 0° to 10° (40 minutes) pass meridian.
- “**Set Behavior**” will determine if the mount will stop tracking or perform a meridian flip at the set position limit.

5.4.7. Track Below Horizon

This function allows the mount to keep tracking an object even if it is below the horizon but can still be seen, for example from an elevated observation site, such as a hill. The power on default is **Prohibited**. One can turn it on when needed.

5.4.8. Set Eyepiece Light

Use this function to adjust the light intensity of iEQ45 Pro illuminated polar scope. If you have an illuminated-reticule eyepiece and has the same socket, you may use this option to adjust its light intensity.

5.4.9. GPS Status

Display if the GPS connection status. GPS ON indicates that the mount is still acquiring the satellite data. GPS OK indicates the link has been established. If neither is displayed, the GPS is malfunctioning. Do not leave the hand controller at this submenu.

5.4.10. Language

Select one of supported menu languages.

5.4.11. Set RA Guiding (CEM25EC Only)

You can turn off R.A. guiding by selecting “**Filter R.A. Guiding**” to allow the high precision encoder to correct the tracking error, or turn the R.A. guiding on by selecting “**Allow RA Guiding**” to allow the mount to receive guiding corrections from the autoguiding software.

5.5. Electric Focuser

This function controls an iOptron electric focuser.

5.6. PEC Option

PEC for short, is a system that improves the tracking accuracy of the drive by reducing the number of user corrections needed to keep a guide star centered in the eyepiece. PEC is designed to improve photographic quality by reducing the amplitude of the worm errors. Using the PEC function is a three-step process. First, the system needs to know the current position of its worm gear so that it has a reference when playing back the recorded error. Next, you must guide for at least 10 minutes during which time the system records the correction you make. (It takes the worm gear 10 minutes to make one complete revolution). This “teaches” the system the characteristics of the worm. The periodic error of the worm gear drive will be stored in the hand controller and used to correct periodic error. The last step is to play back the corrections you made during the recording phase. Keep in mind, the PEC only compensate the RA worm error.

5.6.1. PEC Playback

You can turn “**PEC Playback On**” while you do the tracking, especially for long time astrophotography. The default status is **PEC Playback Off** when the mount is turned on.

5.6.2. Record PEC

Here’s how to record the PE curve manually:

1. Find a bright star relatively close to the object you want to photograph.
2. Insert a high power eyepiece with illuminated cross hairs into your telescope. Orient the guiding eyepiece cross hairs so that one is parallel to the declination while the other is parallel to the R.A. axis.
3. Center the guide star on the illuminated cross hairs, focus the telescope, and study the periodic movement.
4. Before actually recording the periodic error, take a few minutes to practice guiding. Set the hand control slew rate to an appropriate slew rate and practice centering the guide star in the cross hairs for several minutes. This will help you familiarize yourself with the periodic error of the drive and the operation of the hand control. Remember to ignore declination drift when programming the PEC.
5. To begin recording the drive's periodic error, press the **MENU** => “**PEC Option**” => “**Record PEC**”. Once ready to begin recording, press the **ENTER** button to begin. Use the arrow button to keep the guiding star staying at the center of the cross hairs. It takes the worm gear 600 seconds to make one complete revolution. After 600 seconds PEC will automatically stop recording.
6. If you want to re-record the periodic error, select “**Record PEC**” and repeat the recording processes again. The previously recorded information will be replaced with the current information.
7. The PE data needs be recorded again if the power is lost.

5.6.3. PEC Data Integrity

This function will check the recorded PEC data integrity.

5.7. Edit User Objects

Besides various star lists available in the hand controller, you can add, edit or delete your own user-defined objects. This is especially useful for newly found comets. You can also add your favorite observation object into the user object list for easy sky surfing. Up to 60 comets and other user objects can be stored.

5.7.1. Enter a New Comet

Press **MENU** => “**Edit User Objects**” to set user objects.

```
User Defined Comet
Other Objects
```

Select "**User Defined Comet**" to add/browse/delete the user-defined comet list. Find the orbit parameters of a comet in the SkyMap format. For example, the C/2012 ISON has an orbit parameter:

No.	Name	Year	M	Day	q	e	ω	Ω	i	H	G
C/2012	S1 ISON	2013	11	28.7960	0.0125050	1.0000030	345.5088	295.7379	61.8570	6.0	4.0

Select "**Add a New Comet**" to add a new one:

```
Add a New Comet
Browse Comets
Delete a Comet
Clear All Comets
```

The hand controller will display the parameter entry screen:

```
Date: 2000-01-00.0000
q: 0.000000 e: 0.000000
 $\omega$ : 000.0000  $\Omega$ : 000.0000
i: 000.0000
```

Enter the parameters using the arrow buttons and number keys. Press **ENTER** and a confirmation screen will be displayed. Press **ENTER** again to store the object under the assigned user object number, or press **BACK** button to cancel.

5.7.2. Enter Other Objects or Observation List

Press **MENU** => "**Edit User Objects**" to set user objects.

```
User Defined Comet
Other Objects
```

Select "**Other Objects**" to enter you own object:

```
Add a New Object
Browse Objects
Delete an Object
Clear All Objects
```

Select "**Add a New Object**". A screen will be displayed asking you to Enter R.A. and DEC coordinates:

```
Enter R.A. and DEC

R.A.: 00h00m00s
DEC: +00d00m00s
```

You may enter the R.A. and DEC coordinates of the object you want to store, and press **ENTER** to confirm.

A more useful application of this function is to store your favorite viewing objects before heading to the field. When the “**Enter R.A. and DEC**” screen appears, press the **MENU** button. It brings up the catalogs that you can select the object from. Follow the screen instructions to add your favorite objects. Press **BACK** button to go back one level.

Press the **BACK** button to go back to the object entry submenu. You may review the records or delete those that are no longer wanted. Press the **BACK** button to finish the operation. Now you can slew to your favorite stars from “**Custom Objects**” catalog using “**Select and Slew.**”

5.8. Firmware Information

This option will display the mount type, firmware version information for the hand controller (HC), R.A. board (RA), and DEC board (DEC).

5.9. Zero Position

5.9.1. Goto Zero Position

This moves your telescope to its Zero Position. When the power is turned on, the mount assumes the Zero Position. This is the reference point for alignment and GoTo functions.

5.9.2. Set Zero Position

This set the Zero Position for the firmware.

The Zero Position reference will be an undefined value before the first time power on the mount, after firmware upgrade, or HC battery replacement. You can use this function to set the zero position reference.

Press the **ENTER** after moving the mount to Zero Position either manually or with the hand controller.

6. Maintenance and Servicing

6.1. Maintenance

The CEM25/CEM25EC mount is designed to be maintenance free. Do not overload the mount. Do not drop the mount, this will damage the mount or degrade the GOTO tracking accuracy permanently. Use a wet cloth to clean the mount and hand controller. Do not use solvent.

If your mount will not be used for an extended period, dismount the OTAs and counterweight(s).

6.2. iOptron Customer Service

If you have any question concerning your CEM25 mount, please contact iOptron Customer Service Department. Customer Service hours are 9:00 AM to 5:00 PM, Eastern Time, Monday through Friday. It is strongly suggested to send technical questions to support@ioptron.com for prompt response during off hour. Call in the U.S. 1.781.569.0200.

In the unlikely event that the CEM25 mount requires factory servicing or repairing, write or call iOptron Customer Service Department first to receive an RMA# before returning the mount to the factory. Please provide details as to the nature of the problem as well as your name, address, e-mail address, purchase info and daytime telephone number. We have found that most problems can be resolved by e-mails or telephone calls. So please contact iOptron first to avoid returning the mount for repair.

6.3. Product End of Life Disposal Instructions



This electronic product is subject to disposal and recycling regulations that vary by country and region. It is your responsibility to recycle your electronic equipment per your local environmental laws and regulations to ensure that it will be recycled in a manner that protects human health and the environment. To find out where you can drop off your waste equipment for recycling, please contact your local waste recycle/disposal service or the product representative.

6.4. Battery Replacement and Disposal Instructions



Battery Disposal- Batteries contain chemicals that, if released, may affect the environment and human health. Batteries should be collected separately for recycling, and recycled at a local hazardous material disposal location adhering to your country and local government regulations. To find out where you can drop off your waste battery for recycling, please contact your local waste disposal service or the product representative.

Appendix A. Technical Specifications

Mount	Center-Balanced Equatorial Mount (CEM)
Payload	Up to 27 lb (12.3kg), exclude counterweight
Mount weight	10.4 lb (4.7kg)
Payload/Mount weight	2.60
Right Ascension worm wheel	Φ88mm, 144 teeth aluminum
Declination worm wheel	Φ88mm, 144 teeth aluminum
Right Ascension axis shaft	Φ35mm steel
Declination axis shaft	Φ35mm steel
Right Ascension bearing	Φ55mm ball bearing
Declination bearing	Φ55mm ball bearing
Worm gears	Brass
Motor drive	1.8° stepper motor, 128X microdivision
Resolution	0.14 arc seconds
Transmission	Synchronous belt
Latitude adjustment range	0° ~ 60°
Azimuth adjustment range	± 10°
GPS	Internal 32-channel GPS
Polar Scope	AccuAlign™ G2 dark field illuminated
Level indicator	Level bubble
Hand Controller	Go2Nova® 8408 with 150,000 objects database
PEC	PEC/Real time PEC
PE	<0.3 arcsec RMS (CEM25EC only)
Tracking	Automatic
Speed	1×,2×,8×,16×,64×,128×,256×,512×,MAX(1440X)
Counterweight shaft	Φ20mm
Counterweight	10.4 lb (4.7kg)
Tripod	1.5" Stainless Steel(5kg), optional 2"(8kg)
Dovetail saddle	Spring loaded Vixen-style
Power consumption	0.35A(Tracking), 0.6A(GOTO)
Power requirement	12V DC(9 ~ 15V), 1.5Amp
AC adapter	100V ~ 240V (included)
Serial port	Yes (on hand controller)
Autoguide port	Yes
Firmware upgrade	Yes
PC computer control	Yes (ASCOM)
Operation temperature	-10°C ~ 40°C
Warranty	Two year limited

Appendix B. Go2Nova[®] 8408 HC MENU STRUCTURE

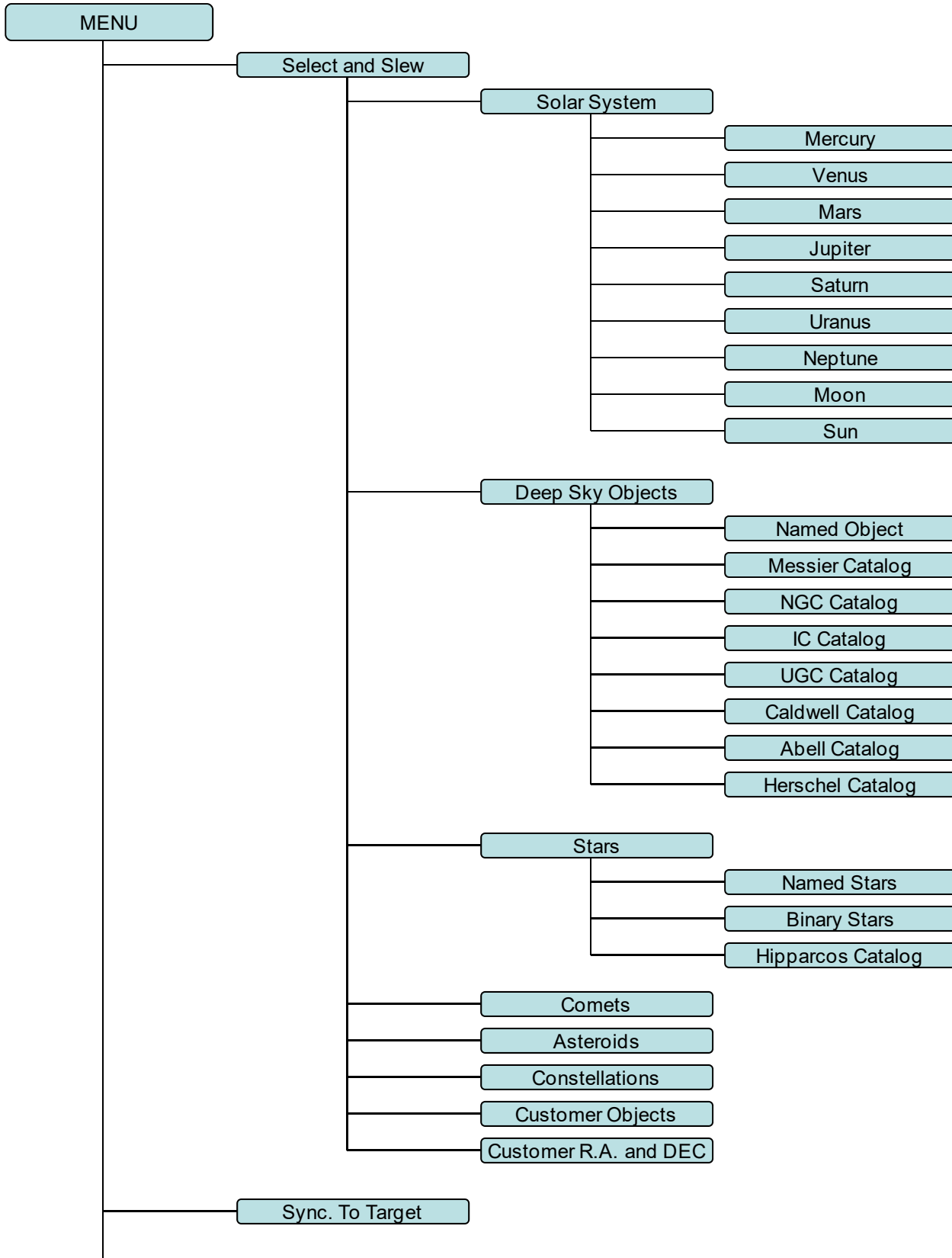

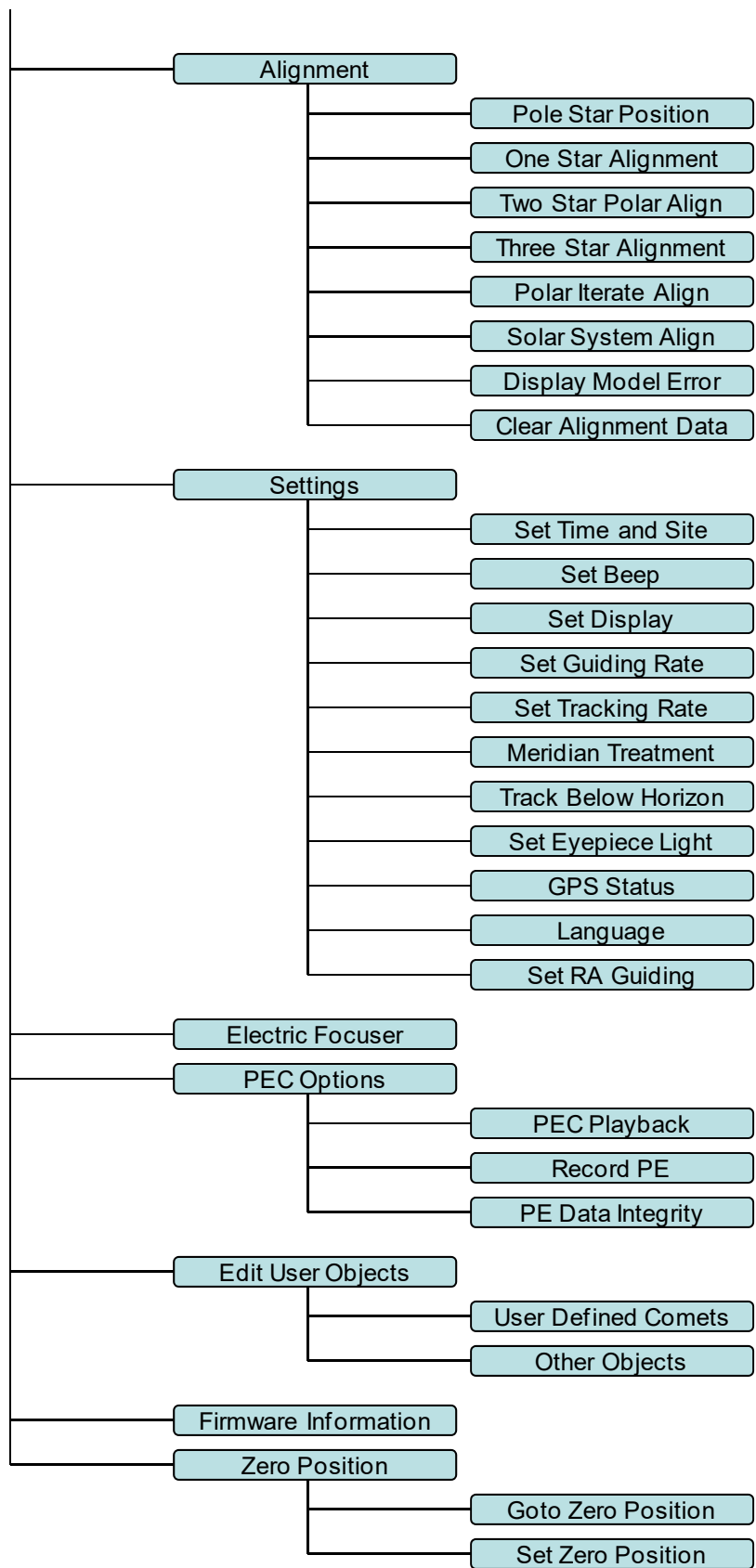

Appendix C. Firmware Upgrade

The firmware in the 8408 hand controller and motor control boards can be upgraded by the customer. Please check iOptron's website, www.iOptron.com, under the product page or Support Directory, select CEM25 or CEM25 EC, for detail.

Appendix D. Computer Control an CEM25 Mount

The CEM25 mount can be controlled by a SmartPhone, a Tablet or a computer. It is supported by two types of computer connections:

- Connect to a computer via RS232 serial port. An optional RS232 to USB adapter (iOptron part #8435) is needed if your computer does not have a serial port, like most of the laptops on the market today. Follow the adapter instructions to install the adapter driver. The mount can be controlled via ASCOM protocol (Windows OS), or directly by some software, such as Sky Safari (Mac OS)
- Connect wirelessly with iOptron StarFi adapter (#8434) or some other third party adapter (may with limited function). The mount can be controlled via ASCOM protocol (Windows OS), SmartPhone/Tablet and Mac OS wirelessly. See StarFi Instruction Manual for detailed information.

To control the mount via ASCOM protocol, you need:

1. Download and install the latest ASCOM Platform, currently 6.1 SP1, from <http://www.ascom-standards.org/>. Make sure your PC meets the software requirement. For 6.1 SP1, Windows XP users should install .NET Framework 4 (not the Client Profile). Windows Vista and Windows 7 users should install .NET Framework 4.5.2. Windows 8 and 8.1 users do not need install any additional components.
2. Download and install the latest iOptron Telescope ASCOM drive for CEM25 from iOptron website.
3. Planetarium software that supports ASCOM protocol. Follow software instructions to select the iOptron Telescope.

Please refer to iOptron website, www.iOptron.com, under the product page, or Support Directory, iOptron ASCOM Driver for more detail.

Appendix E. Go2Nova[®] Star List

Messier Catalog

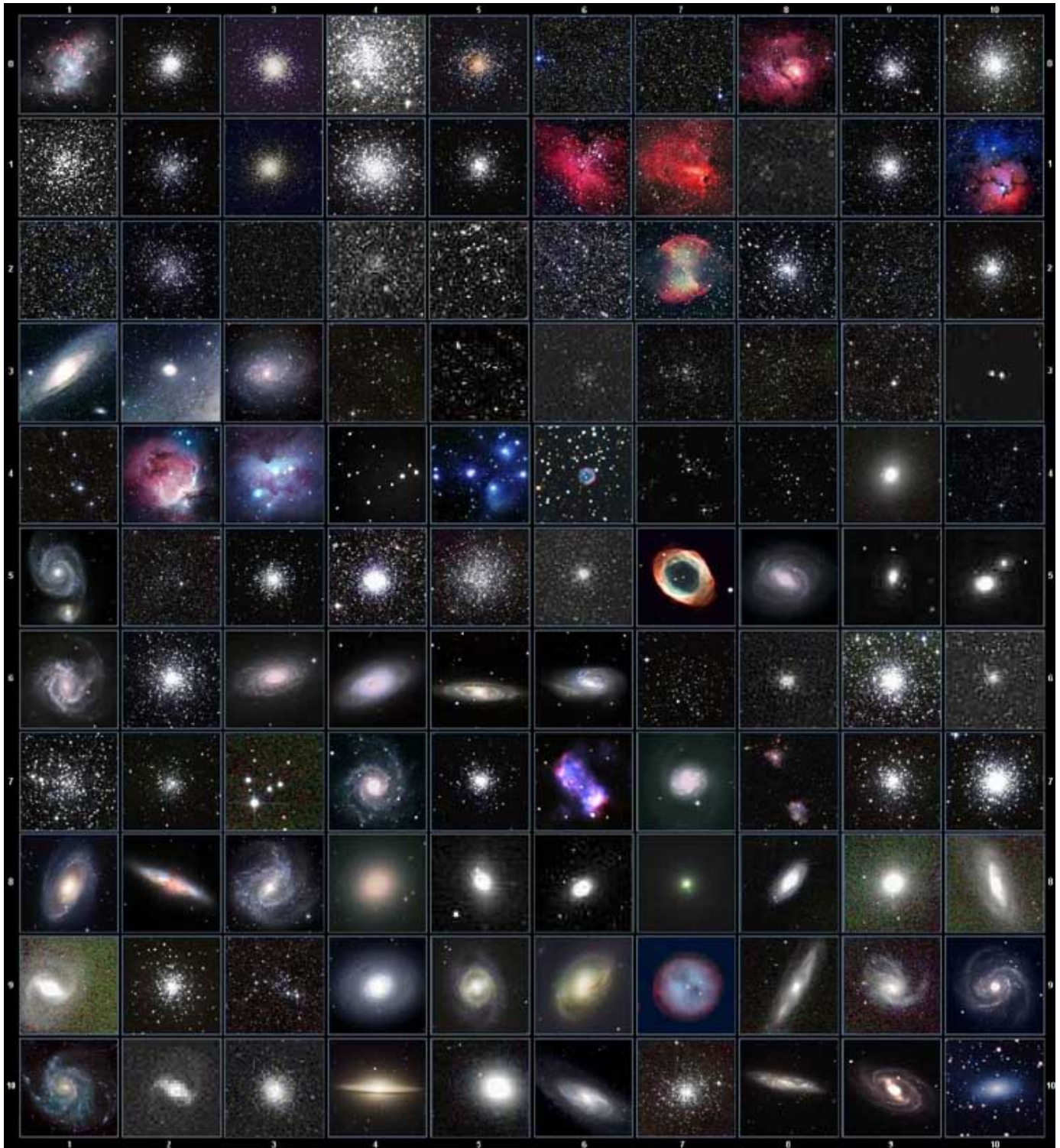

This table is licensed under the [GNU Free Documentation License](#). It uses material from the [Wikipedia article List of Messier objects](#)

Named Star List

001 Acamar	050 Asellus Australis	099 Kaus Media	148 Rastaba
002 Achernar	051 Asellus Borealis	100 Keid	149 Regulus
003 Acrux	052 Aspidiske	101 Kitalpha	150 Rigel
004 Acubens	053 Atik	102 Kochab	151 Rigel Kentaurus
005 Adhafera	054 Atlas	103 Kornephoros	152 Ruchbah
006 Adhara	055 Atria	104 Kurhah	153 Rukbat
007 Al Na'ir	056 Avoir	105 Lesath	154 Sabik
008 Albali	057 Azha	106 Maia	155 Sadachbia
009 Alberio	058 Baten Kaitos	107 Marfik	156 Sadalbari
010 Alchibar	059 Beid	108 Markab	157 Sadalmelik
011 Alcor	060 Bellatrix	109 Matar	158 Sadalsuud
012 Alcyone	061 Betelgeuse	110 Mabsuta	159 Sadr
013 Aldebaran	062 Biham	111 Megrez	160 Saiph
014 Alderamin	063 Canopus	112 Meissa	161 Scheat
015 Alfirk	064 Capella	113 Mekbuda	162 Schedar
016 Algedi	065 Caph	114 Menkalinan	163 Seginus
017 Algenib	066 Castor	115 Menkar	164 Shaula
018 Algiebra	067 Celabrai	116 Menkent	165 Sheiak
019 Algol	068 Celaeno	117 Menkib	166 Sheratan
020 Algorab	069 Chara	118 Merak	167 Sirius
021 Alhena	070 Chertan	119 Merope	168 Skat
022 Alioth	071 Cor Caroli	120 Mesartim	169 Spica
023 Alkaid	072 Cursa	121 Miaplacidus	170 Sterope
024 Alkalurops	073 Dabih	122 Mintaka	171 Sulafat
025 Alkes	074 Deneb	123 Mira	172 Syrma
026 Almach	075 Deneb Algedi	124 Mirach	173 Talitha
027 Alnasl	076 Deneb Kaitos	125 Mirfak	174 Tania Australis
028 Alnilam	077 Denebola	126 Mirzam	175 Tania Borealis
029 Alnitak	078 Dubhe	127 Mizar	176 Tarazed
030 Alphard	079 Edasich	128 Muphrid	177 Taygeta
031 Alphecca	080 Electra	129 Muscida	178 Thuban
032 Alpheratz	081 Elnath	130 Nashira	179 Unukalhai
033 Alrakis	082 Eltanin	131 Nekkar	180 Vega
034 Alrescha	083 Enif	132 Nihal	181 Vindemiatrix
035 Alshain	084 Errai	133 Nunki	182 Wasat
036 Altair	085 Fomalhaut	134 Nusakan	183 Wazn
037 Altais	086 Furud	135 Peacock	184 Yed Posterior
038 Alterf	087 Gacrux	136 Phact	185 Yed Prior
039 Aludra	088 Giasar	137 Phecda	186 Zaniah
040 Alula Australis	089 Gienah	138 Pherkad	187 Zaurak
041 Alula Borealis	090 Gomeisa	139 Pleione	188 Zavijava
042 Alya	091 Graffias	140 Polaris	189 Zosma
043 Ancha	092 Groombridge 1830	141 Pollux	190 Zubenelgenubi
044 Ankaa	093 Grumium	142 Porrima	191 Zubeneschamali
045 Antares	094 Hamal	143 Procyon	192 Barnard's Star
046 Arcturus	095 Homan	144 Propus	193 Kapteyn's Star
047 Arkab	096 Izar	145 Rassalas	194 Kruger 60
048 Arneb	097 Kaus Australis	146 Rasagethi	195 Luyten's Star
049 Ascella	098 Kaus Borealis	147 Rasalhague	

Modern Constellations

No.	Constellation	Abbreviation
1	Andromeda	And
2	Antlia	Ant
3	Apus	Aps
4	Aquarius	Aqr
5	Aquila	Aql
6	Ara	Ara
7	Aries	Ari
8	Auriga	Aur
9	Boötes	Boo
10	Caelum	Cae
11	Camelopardalis	Cam
12	Cancer	Cnc
13	Canes Venatici	CVn
14	Canis Major	CMA
15	Canis Minor	CMi
16	Capricornus	Cap
17	Carina	Car
18	Cassiopeia	Cas
19	Centaurus	Cen
20	Cepheus	Cep
21	Cetus	Cet
22	Chamaeleon	Cha
23	Circinus	Cir
24	Columba	Col
25	Coma Berenices	Com
26	Corona Australis	CrA
27	Corona Borealis	CrB
28	Corvus	Crv
29	Crater	Crt
30	Crux	Cru
31	Cygnus	Cyg
32	Delphinus	Del
33	Dorado	Dor
34	Draco	Dra
35	Equuleus	Equ
36	Eridanus	Eri
37	Fornax	For
38	Gemini	Gem
39	Grus	Gru
40	Hercules	Her
41	Horologium	Hor
42	Hydra	Hya
43	Hydrus	Hyi
44	Indus	Ind

No.	Constellation	Abbreviation
45	Lacerta	Lac
46	Leo	Leo
47	Leo Minor	LMi
48	Lepus	Lep
49	Libra	Lib
50	Lupus	Lup
51	Lynx	Lyn
52	Lyra	Lyr
53	Mensa	Men
54	Microscopium	Mic
55	Monoceros	Mon
56	Musca	Mus
57	Norma	Nor
58	Octans	Oct
59	Ophiuchus	Oph
60	Orion	Ori
61	Pavo	Pav
62	Pegasus	Peg
63	Perseus	Per
64	Phoenix	Phe
65	Pictor	Pic
66	Pisces	Psc
67	Piscis Austrinus	PsA
68	Puppis	Pup
69	Pyxis	Pyx
70	Reticulum	Ret
71	Sagitta	Sge
72	Sagittarius	Sgr
73	Scorpius	Sco
74	Sculptor	Scl
75	Scutum	Sct
76	Serpens	Ser
77	Sextans	Sex
78	Taurus	Tau
79	Telescopium	Tel
80	Triangulum	Tri
81	Triangulum Australe	TrA
82	Tucana	Tuc
83	Ursa Major	UMa
84	Ursa Minor	UMi
85	Vela	Vel
86	Virgo	Vir
87	Volans	Vol
88	Vulpecula	Vul

Deep Sky Object List

ID No.	OBJECT	NGC #	Messier#	IC#	A(Abell)	U(UGC)	ID No.	OBJECT	NGC #	Messier#	IC#	A(Abell)	U(UGC)
1	Andromeda Galaxy	224	31				31	Hind's Variable Nebula	1555				
2	Barnards Galaxy	6822					32	Hubble's Variable Nebula	2261				
3	Beehive Cluster	2632	44				33	Integral Sign Galaxy					3697
4	Blackeye Galaxy	4926	64				34	Jewel Box Cluster	4755				
5	Blinking Planetary Nebula	6826					35	Keyhole Nebula	3372				
6	Blue Flash Nebula	6905					36	Lagoon Nebula	6523	8			
7	Blue Planetary	3918					37	Little Gem	6445				
8	Blue Snowball Nebula	7662					38	Little Gem Nebula	6818				
9	Box Nebula	6309					39	Little Ghost Nebula	6369				
10	Bubble Nebula	7635					40	North American Nebula	7000				
11	Bipolar Nebula	6302					41	Omega Nebula	6618	17			
12	Butterfly Cluster	6405	6				42	Orion Nebula	1976	42			
13	California Nebula	1499					43	Owl Nebula	3587	97			
14	Cat's Eye Nebula	6543					44	Pelican Nebula			5070		
15	Cocoon Nebula			5146			45	Phantom Streak Nebula	6741				
16	Cone Nebula	2264					46	Pinwheel Galaxy	598	33			
17	Cork Nebula	650-51	76				47	Pleiades		45			
18	Crab Nebula	1952	1				48	Ring Nebula	6720	57			
19	Crescent Nebula	6888					49	Ring Tail Galaxy	4038				
20	Draco Dwarf					10822	50	Rosette Nebula	2237				
21	Duck Nebula	2359					51	Saturn Nebula	7009				
22	Dumbbell Nebula	6853	27				52	Sextans B Dwarf					5373
23	Eagle Nebula		16				53	Small Magellanic Cloud	292				
24	Eight-Burst Nebula	3132					54	Sombrero Galaxy	4594	104			
25	Eskimo Nebula	2392					55	Spindle Galaxy	3115				
26	Flaming Star Nebula			405			56	Tank Track Nebula	2024				
27	Ghost of Jupiter	3242					57	Trifid Nebula	6514	20			
28	Great Cluster	6205	13				58	Ursa Minor Dwarf					9749
29	Helix Nebula	7293					59	Whirlpool Galaxy	5194	51			
30	Hercules Galaxy Cluster				2151		60	Wild Duck Cluster	6705	11			

Double Star List

No.	Object	Const	Sep.	Magitude	SAO	Comm. Name
1	Gam	And	9.8	2.3 / 5.1	37734	Almaak
2	Pi	And	35.9	4.4 / 8.6	54033	
3	Bet	Aql	12.8	3.7 / 11	125235	Alshain
4	11	Aql	17.5	5.2 / 8.7	104308	
5	15	Aql	34	5.5 / 7.2	142996	
6	E2489	Aql	8.2	5.6 / 8.6	104668	
7	57	Aql	36	5.8 / 6.5	143898	
8	Zet	Aqr	2.1	4.3 / 4.5	146108	
9	94	Aqr	12.7	5.3 / 7.3	165625	
10	41	Aqr	5.1	5.6 / 7.1	190986	
11	107	Aqr	6.6	5.7 / 6.7	165867	
12	12	Aqr	2.5	5.8 / 7.3	145065	
13	Tau	Aqr	23.7	5.8 / 9.0	165321	
14	Gam	Ari	7.8	4.8 / 4.8	92681	Mesartim
15	Lam	Ari	37.8	4.8 / 6.7	75051	
16	The	Aur	3.6	2.6 / 7.1	58636	
17	Nu	Aur	55	4.0 / 9.5	58502	
18	Ome	Aur	5.4	5.0 / 8.0	57548	
19	Eps	Boo	2.8	2.5 / 4.9	83500	Izar
20	Del	Boo	105	3.5 / 7.5	64589	
21	Mu 1	Boo	108	4.3 / 6.5	64686	Alkalurops
22	Tau	Boo	4.8	4.5 / 11	100706	
23	Kap	Boo	13.4	4.6 / 6.6	29046	
24	Xi	Boo	6.6	4.7 / 6.9	101250	
25	Pi	Boo	5.6	4.9 / 5.8	101139	
26	lot	Boo	38	4.9/7.5/13	29071	
27	E1835	Boo	6.2	5.1 / 6.9	120426	
28	44	Boo	2.2	5.3 / 6.2	45357	
29		Cam	2.4	4.2 / 8.5	24054	
30	32	Cam	21.6	5.3 / 5.8	2102	
31	Alp 2	Cap	6.6	3.6 / 10	163427	Secunda giedi
32	Alp 1	Cap	45	4.2 / 9.2	163422	Prima giedi
33	Pi	Cap	3.4	5.2 / 8.8	163592	
34	Omi	Cap	21	5.9 / 6.7	163625	
35	Alp	Cas	64.4	2.2 / 8.9	21609	Shedir

No.	Object	Const	Sep.	Magitude	SAO	Comm. Name
36	Eta	Cas	12.9	3.5 / 7.5	21732	Achird
37	lot	Cas	2.3	4.7/7.0/8.2	12298	
38	Psi	Cas	25	4.7 / 8.9	11751	
39	Sig	Cas	3.1	5.0 / 7.1	35947	
40	E3053	Cas	15.2	5.9 / 7.3	10937	
41	3	Cen	7.9	4.5 / 6.0	204916	
42	Bet	Cep	13.6	3.2 / 7.9	10057	Alfirk
43	Del	Cep	41	3.5 / 7.5	34508	
44	Xi	Cep	7.6	4.3 / 6.2	19827	Al kurhah
45	Kap	Cep	7.4	4.4 / 8.4	9665	
46	Omi	Cep	2.8	4.9 / 7.1	20554	
47	E2840	Cep	18.3	5.5 / 7.3	33819	
48	E2883	Cep	14.6	5.6 / 7.6	19922	
49	Gam	Cet	2.8	5.0 / 7.7	110707	Kaffaljdhma
50	37	Cet	50	5.2 / 8.7	129193	
51	66	Cet	16.5	5.7 / 7.5	129752	
52	Eps	CMa	7.5	1.5 / 7.4	172676	Adhara
53	Tau	CMa	8.2	4.4/10/11	173446	
54	145	CMa	25.8	4.8 / 6.8	173349	
55	Mu	CMa	2.8	5.0 / 7.0	152123	
56	Nu 1	CMa	17.5	5.8 / 8.5	151694	
57	lot	Cnc	30.5	4.2 / 6.6	80416	
58	Alp	Cnc	11	4.3 / 12	98267	Acubens
59	Zet	Cnc	6	5.1 / 6.2	97646	
60	24	Com	20.6	5.0 / 6.6	100160	
61	35	Com	1.2	5.1/7.2/9.1	82550	
62	2	Com	3.7	5.9 / 7.4	82123	
63	Zet	CrB	6.1	5.0 / 6.0	64833	
64	Gam	Crt	5.2	4.1 / 9.6	156661	
65	Del	Crv	24.2	3.0 / 9.2	157323	Algorab
66	Alp	CVn	19.4	2.9 / 5.5	63257	Cor caroli
67	25	CVn	1.8	5.0 / 6.9	63648	
68	2	CVn	11.4	5.8 / 8.1	44097	
69	Gam	Cyg	41	2.2 / 9.5	49528	Sadr
70	Del	Cyg	2.5	2.9 / 6.3	48796	

No.	Object	Const	Sep.	Magitude	SAO	Comm. Name
71	Bet	Cyg	34.4	3.1 / 5.1	87301	Albireo
72	Omi 1	Cyg	107	3.8 / 6.7	49337	
73	52	Cyg	6.1	4.2 / 9.4	70467	
74	Ups	Cyg	15.1	4.4 / 10	71173	
75	Mu	Cyg	1.9	4.7 / 6.1	89940	
76	Psi	Cyg	3.2	4.9 / 7.4	32114	
77	17	Cyg	26	5.0 / 9.2	68827	
78	61	Cyg	30.3	5.2 / 6.0	70919	
79	49	Cyg	2.7	5.7 / 7.8	70362	
80	E2762	Cyg	3.4	5.8 / 7.8	70968	
81	E2741	Cyg	1.9	5.9 / 7.2	33034	
82	Gam	Del	9.6	4.5 / 5.5	106476	
83	Eta	Dra	5.3	2.7 / 8.7	17074	
84	Eps	Dra	3.1	3.8 / 7.4	9540	Tyl
85	47	Dra	34	4.8 / 7.8	31219	
86	Nu	Dra	61.9	4.9 / 4.9	30450	
87	Psi	Dra	30.3	4.9 / 6.1	8890	
88	26	Dra	1.7	5.3 / 8.0	17546	
89	16&17	Dra	90	5.4/5.5/6.4	30012	
90	Mu	Dra	1.9	5.7 / 5.7	30239	
91	40/41	Dra	19.3	5.7 / 6.1	8994	
92	1	Equ	10.7	5.2 / 7.3	126428	
93	The	Eri	4.5	3.4 / 4.5	216114	Acamar
94	Tau 4	Eri	5.7	3.7 / 10	168460	
95	Omi 2	Eri	8.3	4.4/9.5/11	131063	Keid
96	32	Eri	6.8	4.8 / 6.1	130806	
97	39	Eri	6.4	5.0 / 8.0	149478	
98	Alp	For	5.1	4.0 / 6.6	168373	Fornacis
99	Ome	For	10.8	5.0 / 7.7	167882	
100	Alp	Gem	3.9	1.9 / 2.9	60198	Castor
101	Del	Gem	5.8	3.5 / 8.2	79294	Wasat
102	Lam	Gem	9.6	3.6 / 11	96746	
103	Kap	Gem	7.1	3.6 / 8.1	79653	
104	Zet	Gem	87	3.8/10/8.0	79031	Mekbuda
105	38	Gem	7.1	4.7 / 7.7	96265	

No.	Object	Const	Sep.	Magitude	SAO	Comm. Name
106	Del	Her	8.9	3.1 / 8.2	84951	Sarin
107	Mu	Her	34	3.4 / 9.8	85397	
108	Alp	Her	4.6	3.5 / 5.4	102680	Rasalgethi
109	Gam	Her	42	3.8 / 9.8	102107	
110	Rho	Her	4.1	4.6 / 5.6	66001	
111	95	Her	6.3	5.0 / 5.2	85647	
112	Kap	Her	27	5.0 / 6.2	101951	
113	E2063	Her	16.4	5.7 / 8.2	46147	
114	100	Her	14.3	5.9 / 5.9	85753	
115	54	Hya	8.6	5.1 / 7.1	182855	
116	HN69	Hya	10.1	5.9 / 6.8	181790	
117	Eps	Hyd	2.7	3.4 / 6.8	117112	
118	The	Hyd	29.4	3.9 / 10	117527	
119	N	Hyd	9.4	5.6 / 5.8	179968	
120		Lac	28.4	4.5 / 10	72155	
121	8	Lac	22	5.7/6.5/10	72509	
122	Gam 1	Leo	4.4	2.2 / 3.5	81298	Algieba
123	lot	Leo	1.7	4.0 / 6.7	99587	
124	54	Leo	6.6	4.3 / 6.3	81583	
125	Gam	Lep	96	3.7 / 6.3	170757	
126	lot	Lep	12.8	4.4 / 10	150223	
127	Kap	Lep	2.6	4.5 / 7.4	150239	
128	h3752	Lep	3.2	5.4 / 6.6	170352	
129	lot	Lib	57.8	4.5 / 9.4	159090	
130		Lib	23	5.7 / 8.0	183040	
131	Mu	Lib	1.8	5.8 / 6.7	158821	
132	Eta	Lup	15	3.6 / 7.8	207208	
133	Xi	Lup	10.4	5.3 / 5.8	207144	
134	38	Lyn	2.7	3.9 / 6.6	61391	
135	12	Lyn	1.7	5.4/6.0/7.3	25939	
136	19	Lyn	14.8	5.8 / 6.9	26312	
137	Bet	Lyr	46	3.4 / 8.6	67451	Sheliak
138	Zet	Lyr	44	4.3 / 5.9	67321	
139	Eta	Lyr	28.1	4.4 / 9.1	68010	Aldafar
140	Eps 1	Lyr	2.6	5.0 / 6.1	67309	Double dbl1

No.	Object	Const	Sep.	Magitude	SAO	Comm. Name
141	Eps 2	Lyr	2.3	5.2 / 5.5	67315	Double dbl2
142	Alp	Mic	20.5	5.0 / 10	212472	
143	Zet	Mon	32	4.3 / 10	135551	
144	Eps	Mon	13.4	4.5 / 6.5	113810	
145	Bet	Mon	7.3	4.7/4.8/6.1	133316	
146	15	Mon	2.8	4.7 / 7.5	114258	
147	70	Oph	4.5	4.0 / 5.9	123107	
148	67	Oph	55	4.0 / 8.6	123013	
149	Lam	Oph	1.5	4.2 / 5.2	121658	Marfic
150	Xi	Oph	3.7	4.4 / 9.0	185296	
151	36	Oph	4.9	5.1 / 5.1	185198	
152	Tau	Oph	1.7	5.2 / 5.9	142050	
153	Rho	Oph	3.1	5.3 / 6.0	184382	
154	39	Oph	10.3	5.4 / 6.9	185238	
155	Bet	Ori	9.5	0.1 / 6.8	131907	Rigel
156	Del	Ori	53	2.2 / 6.3	132220	Mintaka
157	lot	Ori	11.3	2.8 / 6.9	132323	Nair al saif
158	Lam	Ori	4.4	3.6 / 5.5	112921	Meissa
159	Sig	Ori	13	3.8/7.2/6.5	132406	
160	Rho	Ori	7.1	4.5 / 8.3	112528	
161	E747	Ori	36	4.8 / 5.7	132298	
162	1	Peg	36.3	4.1 / 8.2	107073	
163	Eps	Per	8.8	2.9 / 8.1	56840	
164	Zet	Per	12.9	2.9 / 9.5	56799	Atik
165	Eta	Per	28.3	3.3 / 8.5	23655	Miram in bevar
166	The	Per	18.3	4.1 / 10	38288	
167	E331	Per	12.1	5.3 / 6.7	23765	
168	Del	PsA	5.1	4.2 / 9.2	214189	
169	lot	PsA	20	4.3 / 11	213258	
170	Bet	PsA	30.3	4.4 / 7.9	213883	
171	Gam	PsA	4.2	4.5 / 8.0	214153	
172	Eta	PsA	1.7	5.8 / 6.8	190822	
173	Alp	Psc	1.8	4.2 / 5.2	110291	Alrisha
174	55	Psc	6.5	5.4 / 8.7	74182	
175	Psi	Psc	30	5.6 / 5.8	74483	

No.	Object	Const	Sep.	Magitude	SAO	Comm. Name
176	Zet	Psc	23	5.6 / 6.5	109739	
177	Kap	Pup	9.9	4.5 / 4.7	174199	
178	Eta	Pup	9.6	5.8 / 5.9	174019	
179	Eps	Scl	4.7	5.4 / 8.6	167275	
180	Bet	Sco	13.6	2.6 / 4.9	159682	Graffias
181	Sig	Sco	20	2.9 / 8.5	184336	Alniyat
182	Nu	Sco	41	4.2 / 6.1	159764	Jabbah
183	2	Sco	2.5	4.7 / 7.4	183896	
184		Sco	23	5.4 / 6.9	207558	
185	Hn39	Sco	5.4	5.9 / 6.9	184369	
186	12	Sco	3.9	5.9 / 7.9	184217	
187	Bet	Ser	31	3.7 / 9.0	101725	
188	Del	Ser	4.4	4.2 / 5.2	101624	
189	Nu	Ser	46	4.3 / 8.5	160479	
190	The	Ser	22.3	4.5 / 5.4	124070	Alya
191	59	Ser	3.8	5.3 / 7.6	123497	
192	Zet	Sge	8.5	5.0 / 8.8	105298	
193	Eta	Sgr	3.6	3.2 / 7.8	209957	
194		Sgr	5.5	5.2 / 6.9	209553	
195	Phi	Tau	52	5.0 / 8.4	76558	
196	Chi	Tau	19.4	5.7 / 7.6	76573	
197	118	Tau	4.8	5.8 / 6.6	77201	
198	6	Tri	3.9	5.3 / 6.9	55347	
199	Zet	UMa	14	2.4 / 4.0	28737	Mizar
200	Nu	UMa	7.2	3.5 / 9.9	62486	Alula borealis
201	23	UMa	23	3.6 / 8.9	14908	
202	Ups	UMa	11.6	3.8 / 11	27401	
203	Xi	UMa	1.8	4.3 / 4.8	62484	Alula australia
204	Sig 2	UMa	3.9	4.8 / 8.2	14788	
205	57	UMa	5.4	5.4 / 5.4	62572	
206	Alp	UMi	18.4	2.0 / 9.0	308	Polaris
207	Gam	Vir	1.4	3.5 / 3.5	138917	Porrima
208	The	Vir	7.1	4.4 / 9.4	139189	
209	Phi	Vir	4.8	4.8 / 9.3	139951	
210	84	Vir	2.9	5.7 / 7.9	120082	

IOPTRON TWO YEAR TELESCOPE, MOUNT, AND CONTROLLER WARRANTY

A. iOptron warrants your telescope, mount, or controller to be free from defects in materials and workmanship for two years. iOptron will repair or replace such product or part which, upon inspection by iOptron, is found to be defective in materials or workmanship. As a condition to the obligation of iOptron to repair or replace such product, the product must be returned to iOptron together with proof-of-purchase satisfactory to iOptron.

B. The Proper Return Merchant Authorization Number must be obtained from iOptron in advance of return. Call iOptron at 1.781.569.0200 to receive the RMA number to be displayed on the outside of your shipping container. All returns must be accompanied by a written statement stating the name, address, and daytime telephone number of the owner, together with a brief description of any claimed defects. Parts or product for which replacement is made shall become the property of iOptron.

The customer shall be responsible for all costs of transportation and insurance, both to and from the factory of iOptron, and shall be required to prepay such costs.

iOptron shall use reasonable efforts to repair or replace any telescope, mount, or controller covered by this warranty within thirty days of receipt. In the event repair or replacement shall require more than thirty days, iOptron shall notify the customer accordingly. iOptron reserves the right to replace any product which has been discontinued from its product line with a new product of comparable value and function.

This warranty shall be void and of no force of effect in the event a covered product has been modified in design or function, or subjected to abuse, misuse, mishandling or unauthorized repair. Further, product malfunction or deterioration due to normal wear is not covered by this warranty.

IOPTRON DISCLAIMS ANY WARRANTIES, EXPRESS OR IMPLIED, WHETHER OF MERCHANTABILITY OF FITNESS FOR A PARTICULAR USE, EXCEPT AS EXPRESSLY SET FORTH HERE. THE SOLE OBLIGATION OF IOPTRON UNDER THIS LIMITED WARRANTY SHALL BE TO REPAIR OR REPLACE THE COVERED PRODUCT, IN ACCORDANCE WITH THE TERMS SET FORTH HERE. IOPTRON EXPRESSLY DISCLAIMS ANY LOST PROFITS, GENERAL, SPECIAL, INDIRECT OR CONSEQUENTIAL DAMAGES WHICH MAY RESULT FROM BREACH OF ANY WARRANTY, OR ARISING OUT OF THE USE OR INABILITY TO USE ANY IOPTRON PRODUCT. ANY WARRANTIES WHICH ARE IMPLIED AND WHICH CANNOT BE DISCLAIMED SHALL BE LIMITED IN DURATION TO A TERM OF TWO YEARS FROM THE DATE OF ORIGINAL RETAIL PURCHASE.

Some states do not allow the exclusion or limitation of incidental or consequential damages or limitation on how long an implied warranty lasts, so the above limitations and exclusions may not apply to you.

This warranty gives you specific legal rights, and you may also have other rights which vary from state to state.

iOptron reserves the right to modify or discontinue, without prior notice to you, any model or style telescope.

If warranty problems arise, or if you need assistance in using your telescope, mount, or controller contact:

iOptron Corporation
Customer Service Department
6E Gill Street
Woburn, MA 01801
www.ioptron.com
support@ioptron.com
Tel. (781)569-0200
Fax. (781)935-2860
Monday-Friday 9AM-5PM EST

NOTE: This warranty is valid to U.S.A. and Canadian customers who have purchased this product from an authorized iOptron dealer in the U.S.A. or Canada or directly from iOptron. Warranty outside the U.S.A. and Canada is valid only to customers who purchased from an iOptron Distributor or Authorized iOptron Dealer in the specific country. Please contact them for any warranty.